

THE MACHINIST

RNI No 71129/98

Volume 10 Issue 6 • June 2015 • Rs 75

www.themachinist.in



Mahindra & Mahindra Ltd.
Igatpuri

Toshiba Transmission and
Distribution Systems (India) Pvt. Ltd. Hyderabad

BrahMos Aerospace
Kanchanbagh, Hyderabad

Hyundai Motor India Limited
Engine - 2, Chennai

Demag Cranes & Components (India) Pvt. Ltd.
(Terex - Material Handling) Co. Ltd. Hyderabad

Cummins Technologies India Pvt. Ltd.
Pithampur

Si2 Microsystems Pvt. Ltd.
Bangalore

Escorts Limited
Faridabad

AND THE 'MACHIE' GOES TO...

The finest of Indian manufacturing
honoured with **The Machinist**
Super Shopfloor 2015 Awards



Cummins Turbo Technologies
India Pvt. Ltd. Dewas

Kirloskar Brothers Limited
Sanand, Ahmedabad

Jaycee Autofab Pvt. Ltd. Faridabad

Sterling Generators Pvt. Ltd.
Silvassa

LG Electronics India Pvt. Ltd.
Greater Noida

AMW Motors Limited
Bhuj

Sigma Electric Manufacturing Corporation Pvt. Ltd.
Pune

Ashok Leyland Limited
Pantnagar

Bajaj Auto Ltd.
Commercial Vehicle Division
Waluj, Aurangabad

Cooper Corporation Pvt. Ltd.

J1/J2 - additional MLC Satara

Volkswagen India Pvt. Ltd.
Chakan, Pune

RSB Transmissions (I) Ltd.
Pune

Mahle Behr India Pvt. Ltd.
Chakan

Farrokh N. Cooper
Cooper Corporation Pvt. Ltd

Amit B. Kalyani
Bharat Forge Ltd.

TATA Lockheed Martin Aero
Hyderabad

RK Behera
Eaton India Hydraulic
Pune

RSB Group
Sudhir Kumar Mishra
BrahMos Aerospace

Solutions For Industry

Perfect, Precision, Progressive Machine Technology

HYUNDAI WIA Machine Tools pours its whole efforts on every process of production and distribution, covering from self-reliant designing to manufacturing and after sales service.



HS Series (HMC)

- Heavy Duty Motion Roller Guidways
- Powerful Dual Wound Spindle Motor
- Heaviest Maximum load in its Class
- Big Plus Spindle (BBT)

F500D/600D (VMC)

- High-precision P4 Angular Contact Bearing main spindle
- Dual Tables for high productivity
- Latest Servo ATC for fastest tool exchange in the class
- Latest SIEMENS 828D Controllers for various software support

E160 Series (CNC Lathe)

- 45° slanted one-piece high rigidity bed structure
- Unbeatable rapid travel speed: **30m/min**
- The most reliable high speed servo turret is adopted: **0.1sec/step**
- Compact design, able to install within a narrow space.
- Ergonomic design allows convenient access to chuck and tool



Machine Tools Line-Up

- CNC Lathe (Horizontal & Vertical)
- Drill Tap Centers
- Vertical Machining Centers
- Horizontal Machining Centers
- CNC Boring Machines

Hyundai Wia India Office

#4/169, Rajiv Gandhi Salai, (OMR), Kandanchavadi,
Chennai - 600 096, Tamilnadu, India

Tel. +91 44 3290 1719

Mob. +91 9840999094

e-mail. sales@hyundai-wia.com, service@hyundai-wia.com

DIE-MOULD SOLUTIONS



KX / K2X Series
Bridge Type
Vertical Machining Centers
K2X 8, K2X 10, K2X 20, KX 10, KX 30



KX Five Series
(5 Axis) Bridge Type
Vertical Machining Centers
K3X 8 Five, K2X 10 Five



VMC Performance Series
C-Frame Type
Vertical Machining Centers
VMC 640 DM, VMC 850 DM, VMC 1050 DM,
VMC 1060 DM, VMC 1260 DM



K Mill Series
Bridge Type
Vertical Machining Centers
K Mill 8, K Mill 10



NX Series
Double Column
Vertical Machining Centers
NX 2215, NX 3215, NX 3222, NX 4222



EX Series
(3-4-5 Axis) Moving Column
Vertical Machining Centers
EX 1280, EX 1680, EX 2480

KX Large Series (5-Axis) Double Column Vertical Machining Centers KX 50 M, KX 50 L, KX 100, KX 200, KX 300

JYOTI CNC is having the largest range of machines for all of metal cutting applications across entire Indian machine tool industry. We commit our best efforts to deliver the best application solutions through the widest machine range enhanced by our customized solution expertise.

Die-Mould Solutions caters to machining of simple profile to complex 3D profiles from small to large size applications delivering best dynamics, accuracy and finish with quick acceleration / deceleration movements and ability to effectively work in repeated start-stop operations. Designed to work on any hardened material with HSM capability these solutions are capable to work for high power requiring roughing operations till light milling precision passes delivering perfect geometry with accuracy and best surface finish.

- State-of-Art Structural Design
- Optimized Surface Quality
- Better Dynamics
- Complex Application Ability

MAKE IN INDIA



JYOTI CNC AUTOMATION LTD.

G - 506, G.I.D.C. Lodhika, Village : Metoda, Dist : Rajkot - 360 021, Gujarat (INDIA).
Ph. : + 91-2827-306100/101, 287081/82 | Fax : + 91-2827-306161/287811

f /JyotiHuron /JyotiHuron /JyotiHuron

web : www.jyoti.co.in / www.huron.fr

E-mail : info@jyoti.co.in, sales@jyoti.co.in

One Stop Solution
for metal cutting

Ahmedabad : +91-79-26921309, +91-99798 62231, Aurangabad : +91-95455 10255, Bangalore : +91-80-23472544, +91-97390 01092, Belgaum : +91-97390 01091, Chennai : +91-44-26253813, +91-99625 62501, Coimbatore : +91-99625 62511, Faridabad : +91-98186 82650, Hosur : +91-99625 62783, Hyderabad / Secundrabad : +91-97032 16651, Indore : +91-99789 11214, Jaipur : +91-97833 07603, Jamshedpur : +91-75490 00992, Kanpur : +91-93368 33783, Kolhapur : +91-97644 42654, Kolkata : +91-33-24618635, +91-98361 13939, Ludhiana : +91-98728 88746, Mumbai : +91-22-26850044, +91-98204 27984, Nagpur : +91-97644 42662, Nasik : +91-97644 42660, New Delhi : +91-11-47791193, +91-99991 91193, Pune : +91-20-66305452, Sriperumbudur : +91-89398 24662, Surat : +91-99798 62235, Vadodara : +91-99798 62232

Super Event for a Super Industry!

Our Awards ceremony can be easily termed as a National Event! The locations from which people travelled for the inaugural edition of The Machinist Super Shopfloor Awards span the length and breadth of India. Top manufacturing professionals came from Ahmedabad to Aurangabad, from Bangalore to Bhuj, from Chakan to Coimbatore, from Kancheepuram to Walchandnagar, from Nasik to Noida, from Pantnagar to Pithampur, from Dewas to Delhi, from Satara to Silvassa...The list simply goes on. Add to this the names of the manufacturing brands that participated and it all sums up to a grand get together of Indian manufacturing. The presence of Shri Kalraj Mishra, Union Minister of MSME, Government of India, as the Chief Guest added to the charm - and so did the active participation from some of India's finest CEOs as well as the involvement of our esteemed jury members.

And as GK Pillai, MD & CEO, Walchandnagar Industries Ltd. remarked to me during the event, it is not always that such luminaries come together on one single platform: "To have a gathering like this with some of the most important people from the industry coming together and to have them to discuss and deliberate on a crucial subject is a rare occasion. You and The Machinist team are giving a big impetus to this segment," he said. The credit goes to all of you out there who have made this possible. After the awards ceremony, one of the attendees walked up to me and said that this is just the kind of event that Indian manufacturing industry deserves. He couldn't have put it better. Indeed, a Super Industry deserves a Super Event like this!

Well, this is just the beginning. We are (already!) brainstorming on another really interesting and magnificent forum. You will soon know! In the meanwhile, enjoy the coverage of this event and keep sharing your feedback.



Editor & Chief Community Officer

"TO HAVE A GATHERING LIKE THIS WITH SOME OF THE MOST IMPORTANT PEOPLE FROM THE INDUSTRY COMING TOGETHER... IS A RARE OCCASION."

Editorial Advisory Board



Aravind Melligeri,
Chairman and CEO,
Aequis.

Works towards making India a leading hub for high quality precision manufacturing & aerospace



GK Pillai, MD and
CEO, Walchandnagar
Industries Ltd.

Brings the best of the public and private sectors for the benefit of the manufacturing industry



Nitin Chalke, MD –
India, Eaton.

Combines the understanding and expertise of five business segments to provide visionary leadership



Viren Joshi, CEO
and President, Sigma
Electric Manufacturing
Corporation.

Blends the proficiency of growing new businesses and managing growth at large MNCs

THE MACHINIST

Volume 10 Issue 6 June 2015



CHIEF EXECUTIVE OFFICER
Deepak Lamba

CHIEF FINANCIAL OFFICER
Subramaniam S

PUBLISHER, PRINT & PRODUCTION CONTROLLER
Joji Varghese

EDITOR & CHIEF COMMUNITY OFFICER | Niranjan Mudholkar
niranjan.mudholkar@wwm.co.in +91 9819531819

ASSISTANT ART DIRECTOR | Sanjay Dalvi
sanjay.dalvi@wwm.co.in

SUBSCRIPTIONS

subscriptions.rmd@timesgroup.com
022 22733274 / 66354083

BRAND PUBLISHER | Rishi Sutrave
rishi.sutrave@wwm.co.in +91 9820580009

ADVERTISING

SOUTH | Mahadev B
mahadev.b@wwm.co.in +91 9448483475

WEST | Ranjan Haldar
ranjan.haldar@wwm.co.in +91 9167267474

NORTH | Shashin Bhagat
shashin.bhagat@wwm.co.in +91 98250 13439

Printed and published by Joji Varghese for and on behalf of owners Worldwide Media Pvt Ltd (CIN:U22120MH2003PTC142239), The Times of India Building, Dr DN Road, Mumbai 400001. Printed at JRD Printpack Private Limited, 78, Resham Bhavan, 7th Floor, Veer Nariman Road, Churchgate, Mumbai - 400 020. Editor: Niranjan Mudholkar. Published for June 2015.

Disclaimer: All rights reserved worldwide. Reproducing or transmitting in any manner without prior written permission prohibited. All photographs, unless otherwise specified, are used for illustrative purposes only. The publisher makes every effort to ensure that the magazine's contents are correct. However, we accept no responsibility for any errors or omissions and accept no responsibility for any loss or damage caused as an effect thereof. The information provided in this publication is for general use and may not be appropriate for the specific requirements and / or conditions of the reader/s. The opinions expressed by experts are their own and in no way reflect those of the publisher.

RELIABILITY. PRICE. REPUTATION.



and Performance!



Haas DM-1 Small-Footprint, High-Speed Drill/Mill Center

= TOTAL CUSTOMER VALUE.

WE KNOW what it's like.
We're MACHINISTS, too.
We CUT METAL every day.

That's why we're driven to make sure that every Haas CNC machine is **trustworthy**, affordable, and always backed by the industry's **best after-sale** service.

Haas Factory Outlet | www.HaasCNC.com

Sales: Ahmedabad: 079-32405007, Bangalore: 080-41179452/53, Chennai: 044-65156052, Coimbatore: 0422-2413924
Delhi: 0124-4367619, Kolhapur: 0231-2677979, Mumbai: 022-39136041, Pune: 020-32935433

Service: North: 09312550550, West (Guj) and Central: 09376150150
West (Mah) and East: 09325150150, South: 080-41179452/53



CONTENTS



AWARDS **54**
 And the 'Machie' goes to...

Event - Intec 2015
Technology advancement
 - need of the hour..... **24**



AEROSPACE **14**
 Preparing for the leap



IT in Manufacturing
 Make it Better in India **40**

Editorial 4
 News 8
 Event Calendar 12
 Case Study: Direct Digital Manufacturing 20
 Interview: Ensuring optimum performance 36
 Machine Tools: Passion and precision 44
 Event: Six Haas machines at IMTOS 48
 Products 76



Automotive **50**

Offering solutions and services to secure the quality of aid.

We offer dedicated solutions that include tool design and high service level to secure quality and reduction in manufacturing costs.



SMART MIRACLE

Revolutionary performance for difficult-to-cut materials



VP05RT/ VP10RT

A good balance of wear and fracture resistance for turning Co-Cr Alloy and Titanium Alloy



MMS Drill

Beyond the bounds of common sense for Stainless steel drilling, TRI-Cooling Technology



Small Tools

Ideal for complicated small parts machining with automatic lathes



MMC Hardmetal India Pvt. Ltd.

A Subsidiary of **MITSUBISHI MATERIALS**

H.O.: Prasad Enclave, #118/119, 1st Floor, 2nd Stage, 5th Main, BBMP Ward #11, (New #38), Industrial Suburb, Yeshwanthpura, Bengaluru - 560 022, Karnataka, India.
Tel : +91 80 3080 7400 to 3080 7499 | Website : www.mitsubishicarbide.com

STRONGER



FASTER



SUPERIOR



TOTAL SOLUTIONS



DRILLING



MILLING



TURNING



THREADING & GROOVING



NEWS

India-US sign the 2015 Framework for Defence Relationship; review emerging dynamics

During an official visit to India, Dr. Ashton Carter, the United States Secretary of Defence, met India's Defence Minister Manohar Parrikar and called on Prime Minister Narendra Modi. Defence Minister Manohar Parrikar and Secretary Carter discussed the India-US defence relationship, and the broader India-US Strategic Partnership, and reaffirmed their commitment to expand and deepen the bilateral defence relationship. The two also reviewed the existing and emerging regional security dynamics.



Parrikar has also in-principle accepted Carter's invitation to the US

They signed the 2015 Framework for the India-US Defence Relationship, which builds upon the previous framework and successes to guide the bilateral defence and strategic partnership for the next ten years. The new Framework agreement provides avenues for high level strategic discussions, continued exchanges between armed forces of both countries, and strengthening of defence capabilities. The Framework also recognises the transformative nature of the Defence Technology and Trade Initiative (DTTI).

PMI up in May with rise in output growth and new orders

The upturn in the Indian manufacturing sector gathered pace in May, with levels of production and new orders rising at the fastest rates since the opening month of 2015. A further increase in input costs was seen and, consequently, charges were raised following a decline seen in the preceding month. Up to a four-month high of 52.6 in May, from 51.3 in April, the seasonally adjusted HSBC India Purchasing Managers' Index (PMI) signalled a further improvement in business conditions.

Also, gains were seen in all three

monitored sub-sectors. Manufacturing output increased for the nineteenth month running, with the rate of growth marked and the fastest since January. The sharpest rise was reported by consumer goods producers. Commenting on the survey, Pollyanna De Lima, Economist at Markit said: "PMI data signalled a further robust expansion of the

Indian manufacturing economy in May. Both output and new order growth accelerated to 4-month highs, whereas the rise in export orders lost traction."



Manufacturing output increased for the nineteenth month running

Mitsubishi Electric to build elevator factory in India

Mitsubishi Electric Corporation has announced that Mitsubishi Elevator India Private Limited will build a factory in Bangalore, India, aiming to strengthen local competitiveness and expand business in the world's second largest market for elevators and escalators. India's elevator and escalator market, which has grown in step with

the country's rapid economic development, is now the world's second largest, next to China. Annual demand rose to 47,000 units in 2014 and is expected to continue growing. By producing locally, Mitsubishi Electric expects to strengthen product competitiveness in terms of price and delivery time, focusing especially on its NEXIEZ-LITE model.

HAL-BAeS sign MoU for more collaboration

HAL signed an MoU with BAe Systems UK recently for Hawk Mk132 Upgrade, development of combat Hawk for Indian and export markets and maintenance solutions for supporting Jaguar and Hawk fleet. Speaking on the occasion, T. Suvarna Raju, CMD, HAL expressed confidence on success of the proposed collaboration between HAL and BAeS. "It is important that both the teams



The MoU is for the Hawk Mk132 Upgrades

finalise the scope of Hawk Mk132 Upgrades and other work packages under the MoU agreement at the earliest," he said. MN Shrinath, General Manager (Aircraft) signed the MoU on behalf of HAL, while Steve Timms, Managing Director (Defence Information, Training and Services) signed on behalf of BAeS. Chris Boardman, Managing Director (Military Air & Information) headed the BAeS delegation.



**Probably the best
drill in the world -
CERATIZIT MaxiDrill 900**

Andreas Kleinhans
Product Manager, Drilling

**CERATIZIT MaxiDrill 900 product range.
Technically superior and simply user-friendly.**

Your production : more efficient
Handling : easier
Machining process : more stable
Application potential : universal
Product range : more comprehensive



Head Office and Works:
Ceratizit India Pvt.Ltd
58,Motilal Gupta Road, Barisha, Kolkata - 700 008
Tel:+91 33 2494 0581/0335/6382 Fax: +91 33 2494 1472/5839
Email:ctindia.info@ceratizit.com; Ctindia.marketing@ceratizit.com
www.ceratizit.com

Works:
G.W. Precision Tools India Pvt. Ltd.
Plot:124- A, Bommasandra Industrial Area, Anekal Taluk,
Bengaluru - 560 099, Phone: +91-80-40431252, Fax : 91-80-40431254,
Email: application@gwindia.in, www.gwindia.in,   



Government gives a big push to private participation in defence manufacturing

There was a long standing demand of the Private Sector Manufacturers to bring parity between Domestic Private Players with Ordnance Factory Board and Defence PSUs in the matter of payment of Central Excise and Customs Duty. As a major game changer, Government of India has withdrawn excise and customs duty exemptions presently available to goods manufactured and supplied to Ministry of Defence by Ordnance Factory Board and Defence PSUs vide Notifications



Test firing of the Aakash Missile. File pic.

No. 23/2015-Central Excise and No. 29/2015-Customs dated 30.04.2015. This will provide a level playing field to Domestic Private Players bidding for the Government contracts by tak-

ing away the strategic advantage with PSUs for quoting lower rates in open bids. With this initiative, the Government has also fulfilled demand of foreign Original Equipment Manufacturers (OEMs) such as Boeing, Airbus, Lockheed Martin, BAE Systems etc. who are actively exploring the scope of future investments in India. The recent Notification from Department of Revenue will provide a definitive message to foreign OEMs that India is open to business.

Omron Automation expands its presence in Western India

Following its regional expansion strategy for this FY, Omron Automation India, part of Omron Japan, announced the opening of its new office in Ahmedabad. Situated in Shahibaug,

ron's business strategy. The state is one of the major industrial hubs in India and this expansion of our infrastructure would contribute a lot in strengthening our presence via servicing current & potential customers in a better and more efficient manner. This would also serve as a centre to cater to adjoining regions namely north and south Gujarat such as Gandhidham, Kutch, Morbi, Rajkot, Jamnagar and the industrial belts of Waghodia, Jhagadia, Hajira and Dahej falling under Baroda and Surat regions." The current focus areas



Sameer Gandhi, MD, Omron Automation India lighting lamp at the Ahmedabad office inauguration

of the company are the large and medium manufacturing enterprises from Packaging, Pharma, Special Purpose Machines (SPM), Batch Mixing OEMs & Automotive sectors in these regions.

of the company are the large and medium manufacturing enterprises from Packaging, Pharma, Special Purpose Machines (SPM), Batch Mixing OEMs & Automotive sectors in these regions.

Volkswagen India appoints Dr. Andreas Laueremann as new President & MD

Dr. Andreas Laueremann has been appointed as the new President & MD, Volkswagen India Pvt. Ltd. with effect from July 1, 2015. He will succeed Mahesh Kodumudi, who will take over a responsible position with Volkswagen Group of America with effect from June 1, 2015. Kodumudi will continue to act in an Advisory Role to Volkswagen Group India. Dr. Laueremann (53) holds a doctorate degree from the University of Passau and Technical University Munich. He started his career with TCW Tranfer-Centrum for Production Logistics and Technology Management in Munich before joining Volkswagen AG in 1997. Dr. Laueremann moved to Volkswagen Argentina in Pacheco in 2007 as GM, RPU Division. In 2010 he took over the lead of Central Industrial Engineering and Optimization of Indirect Areas of the Volkswagen Group and in 2012, he took charge as the Head of Central Planning for FAW-VW in China. He returned to Volkswagen, Wolfsburg at the start of 2015.



Haier announces plans to expand its Ranjangaon facility

Haier has announced mega investment plans for expansion of the company's manufacturing facility in the country as part of the Indian government's 'Make in India' agenda. The investment plans to expand Haier's existing manufacturing facility at Ranjangaon, Pune has resulted after a Memorandum of Understanding was signed between the Govt. of Maharashtra and

Haier Group in China. The proposed investment of Rs370 crore will scale up manufacturing operations of the company in India by introducing production of new product lines like, washing machines, air conditioners, LED panels, water heaters and deep freezers, apart from refrigerators. By 2017, Haier plans to increase the manpower by 120 percent to 2600 employees, across India.



Multi-tasking Turning Center

PUMA SMX series

Doosan's next generation Multi-tasking Turning Center, features high productivity, high precision and easy operation.



Productivity

- Complex machining capabilities of left spindle, right spindle, B-axis and milling spindle
- High-rigidity machine construction using structural analysis design
- Maximized Y-axis machining area through orthogonal design structure



Accuracy

- Minimized thermal deformation of the spindle and feed axis using oil cooler
- Adoption of Roller LM Guideways with high-rigidity and high precision
- Equipped with 0.0001° B-axis and C-axis accuracy control function



Convenient

- Front located tool magazine
- Side-to-side movable swiveling operation panel with adjustable height
- Convenient ATC - MAGAZINE operation panel

PUMA SMX Series

Super Multi-tasking Turning center
PUMA SMX2600 / PUMA SMX2600S
PUMA SMX3100 / PUMA SMX3100S





Mark your diary

A list of key events happening between July 2015 to March 2016, both nationally and internationally

India Warehousing Show

July 1-3, 2015, New Delhi

<http://indiawarehousingshow.com/>

Automotive Engineering show

July 7-9, 2015, Chennai

automotive-engineering-show.in.messefrankfurt.com

Automation 2015

August 24-27, 2015, Mumbai

www.iedcommunications.com/index.php

Aluminium India 2015

September 7-9, 2015, Mumbai

<http://www.aluminium-india.com/>

Laser World of Photonics

September 9-11, 2015, New Delhi

www.world-of-photonics-india.com/

IMTS 2016

September 12 - 17, 2016, Chicago (US)

www.imts.com

Global Additive Manufacturing Summit - 2015

September 24 - 25, 2015, Bangalore

<http://www.amsi.org.in/Conference.htm>

EMO MILANO 2015

October 5-10, 2015, Milan

www.emo-milano.com/en/home

FABTECH 2015

November 9-12, 2015, Chicago, USA

www.fabtechexpo.com

Global SME Business Summit 2014

December 07-08, 2015, New Delhi

<http://ciisme.in/>

IMTEX FORMING 2016 & Tooltech 2016

January 21-26, 2016, Bengaluru (BIEC)

www.imtex.in

IPC APEX EXPO

March 13-17, 2016, Las Vegas (US)

www.ipcapexexpo.org/html/default.htm

Machine Tool Expo

August 20-23, 2015

Delhi

www.mtx.co.in

September 24-27, 2015

Gandhinagar

www.mtx.co.in



Innovation is not an option but an ATTITUDE

Can be mounted on
horizontal table
for VMC's and on
Vertical tomb stones for HMC's

Guide ways hardened to 64HRC,
provides better accuracy
for longer period

Replaceable jaws
for easy customization

Chip cleaning slots
for easy cleaning

Inbuilt hydraulic pressure booster
provides incredible 4000kgf (40KN)
variable clamping pressure

Input pressure can be :
- 6Bar Pneumatic pressure or
- 500 Bar single acting
hydraulic pressure

Two directional tennon slots
for accurate mounting on
base plates or tomb stones

ARNOLD TWIN AUTOMATIC VICE

For High Volume Production

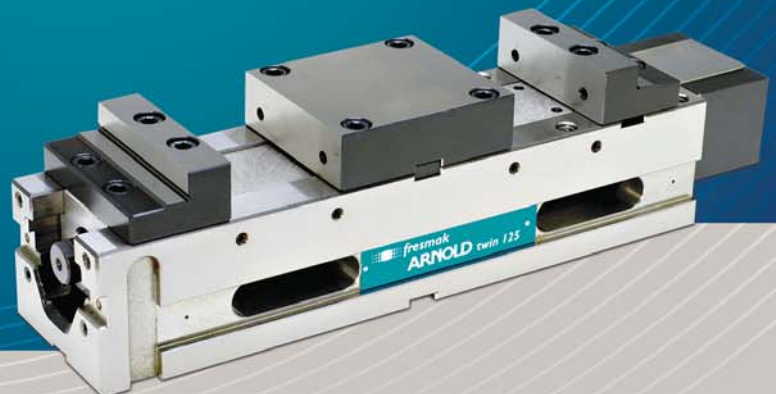

Fresmak ARNOLD Precision Engineering Pvt. Ltd.
Millennia Towers, Level 1, Tower B,
No. 1 & 2, Murphy Road, Ulsoor, Bangalore - 560 008, India.
Phone No. : +91 (80) 6765 4250 | Fax No. : +91 (80) 6765 4033
Email: info.india@fresmak.com | www.fresmak.com

fresmak
ARNOLD

Subsidiary of Fresmak, Spain



File picture of Indian Air Force Sukhoi Mki fighter aircraft in victory formation, during Air Force Day Parade in 2014

Preparing for the leap

To prepare for the growth in aerospace manufacturing, Indian suppliers need to have their flight path chalked out and opportunities and challenges understood.

By Rajiv Chib

Moving into 2015, the commercial jet market continues to grow at record levels, with the Boeing 787, 777X, 737 MAX, and Airbus A350 XWB, A320neo, and A330neo programs marking the stellar performers. The backlog of aircraft orders is expected to grow, with increasing passenger demand and airlines continuing to update their fleets with new fuel-efficient aircraft in order to stay competitive.

On the flip side, commercial aircraft manufacturers are expected to stay under pressure to reduce supply chain costs with lower tier suppliers challenged by the requirement of investing in skills development, tooling and manufacturing capacity. Outsourcing on the whole is likely to increase as military and commercial customers alike are enforcing that the value of their purchases be “offset”, by placing work in respective countries of origin. OEMs and Tier 1s will be balancing the requirement of keeping jobs at home and the desire to maximise revenues and minimise labour costs in low cost countries.

The regional jet market is likely to find new OEM entrants from the East namely from China (with its ARJ21), Japan (with Mitsubishi’s MRJ), and Russia (with the SSJ100). Emerging markets offer low cost ad-

vantages; however, the aerospace industry’s push into emerging markets until now has been relatively slow. This could be due to several distinctive attributes of the aerospace industry like the complexity of the industry’s technology; regulatory, quality, and safety requirements; and the critical importance of protecting intellectual property especially in areas such as aircraft engine design or avionics.

Aerospace manufacturing volumes are also typically lower than those in other industries, whereas the level of design and production customisation is higher. However, the future offers opportunities to players such as AVIC I in China, Sukhoi in Russia, Hindustan Aeronautics (HAL), Dynamics, and Tata Advance Systems in India, to take their place as low-cost aerospace manufacturing and engineering suppliers to the world. There is also a high probability that by 2020, China could become the preferred location of global players for manufacturing of simple airframes, Russia for modules of aircraft engines and India for avionics and detailed engineering. To prepare for this, potential aerospace suppliers need to have their flight path chalked out and opportunities and challenges understood.



Outsourcing on the whole is likely to increase as military and commercial customers alike are enforcing that the value of their purchases be “offset”, by placing work in respective countries of origin.”

The Make in India opportunity

Due to the increasing demand in A&D equipment for the armed forces, India continues to

ORION

SERIES

Next-Gen

Horizontal Machining Centers



*Result of Indo-German engineering
Versatile cutting performance
Best in class accuracy*

Smartphone access: http://www.bfwindia.com/bfw-feedback/feedback_form.php

 www.facebook.com/bharatfritz.werner

Toll free: 18004253332

service@bfw.co.in

Making it Easier



German Subsidiary

matec
MASCHINENBAU

BFW

BHARAT FRITZ WERNER

An ISO 9001:2008 and ISO 14001:2004 Machine Tool Manufacturer

www.bfwindia.com | bfwmarketing@bfw.co.in



be one of the promising A&D markets in the world. Major milestones in certain deals are expected to be achieved in 2015, with programs such as the MMRCA, Avro replacement, and Light utility, attack and transport helicopter procurements. This could result in more overseas companies becoming involved in the Indian market with joint ventures or co production arrangements. The governments' focus on the "Make in India" campaign accompanied by announcement of SEZs and aerospace parks, is also expected to give a thrust to manufacturing in the country's aerospace industry. Select state governments are also introducing Single Window Clearance Committees and the State High Level Clearance Committees with the objective of clearing proposals in a speedy manner. Besides, states like Karnataka and Gujarat are making efforts to ensure that the infrastructure requirements of the industry are met by earmarking land in excess of thousand acres to be devoted to the expansion of aerospace activities and aerospace universities. The Ministry of Defence is in the process of revising and liberalising the defence offset guidelines which are

vanced Systems are also increasingly becoming the preferred supplier of aero structure parts and assemblies for OEMs such as Airbus, Boeing, Ruag, Pilatus and Bell Helicopter.

To attract aerospace outsourcing into India, aerospace manufacturing companies must possess the desired technological and managerial expertise required in line with global best practices. Moreover they must also be prepared to face the challenges, difficulties and peculiarities of a global aerospace supply chain supplier which may include:

- Dealing with foreign exchange fluctuations
- Competition from other low cost countries
- Managing OEMs requirements of sharing technology risks with suppliers
- Need for certifications
- Need to achieve scale to sustain operations

Best Practices – for the global supply chain

Every supplier endeavours to be part of a global supply chain.

To stand out from other competitors or when attempting to replace an existing supplier/subcontractor of a foreign OEM, Indian companies/Indian offset partners must have the ability to demonstrate their competitive advantages and the benefits that the client can gain from a commercial relationship. Though products vary, the requirements and prerequisites desired by OEMs are more or less similar (Aero Montreal, *Becoming a World-Class Supplier in Aerospace: Prerequisites and Best Practices*). Indian companies will do well to keep the following requirements of OEMs in mind when interacting with potential partners:

- OEMs consider the total acquisition cost and not only prices in their evaluation of suppliers. The total acquisition cost takes account of all the costs related to purchasing the product (transportation, quality, utilisation, certification, etc.).
- OEMs want assurances that the supplier is not financially at risk and therefore requires details of the supplier's financial statements, internal ratios and ratios published by trade and financial information companies.
- The supplier is required to have the capacity and financial resources to respond to growth of orders (available space, equipment, expansion, etc.).
- Defence programs have relatively large project execution timeframes, sometimes running into decades, Suppliers will be accessed on their capability to sustain their business over extended periods to become reliable partners
- The supplier may have to accept the OEM's general conditions (flexibility of orders or payments, guarantees, deliveries, etc.) and technical conditions (parts marking, packaging, inspections, certificates, etc.). These conditions would be unique to each OEM.



Prime Minister Narendra Modi inside an aircraft onboard INS Vikramaditya, in Goa on June 14, 2014. The PM's push for Make in India in Aerospace and defence manufacturing will have a major impact on this industry

likely to follow the basic theme of boosting indigenisation, improving the inflow of investment and promoting transfer of technology. Overall these measures are expected to provide an impetus to the indigenisation process in the aerospace manufacturing sector by giving larger opportunities in a liberalised environment.

Though India's aerospace industry was initially mainly concentrated in design, engineering and IT solutions, aerospace manufacturing has witnessed a strong spurt in the past couple of years. Even foreign companies like the United States-based UTC Aerospace Systems have been granted approval from the US Federal Aviation Authority for manufacture of aircraft parts in India — a four-person life-raft developed by the Indian arm of UTAS and nickel-cadmium batteries developed by Hyderabad-based HBL Power Systems. Moreover, Indian companies like Dynamatic Technologies and Tata Ad-

IWK 4000.5000 / 6000.7000

Your investment for greater productivity

IWK 4000.5000
(HSK - A63 / BT40)



IWK 6000.7000
(HSK - A100 / BT50)



“High Performance” Horizontal Machining Centres for TRANSPORT, INDUSTRIAL & ENERGY SECTORS from the global leader STARRAG; German technology proudly Made-In-India; THE FIRST EUROPEAN company established in India to manufacture horizontal machining centres.

The CUSTOMER focus is to get triple benefits of productivity, quality & uptime, thus maximising customer’s Overall Equipment Effectiveness (OEE). Long-term ACCURACY, Long-term RELIABILITY and Long-term PRODUCTIVITY are the hallmarks of WMW.



The machine is designed with the proven know-how of WMW with many innovative ideas, based on the 125 years of Heckert experience & constant technology up-gradation, oriented towards the reduction of the non-productive idle and set-up times, thereby increasing the Productivity!

IWK series are rolled out from the Indian facility. Products are Innovative, International, Intelligent & Indianised. IWK machines are available in INR from our world-class fully air-conditioned facility at Bangalore, together with expertise in tooled up solutions which is our key strength. We offer application and service support nationally, with spare parts support from Bangalore.



Starrag India Private Limited

No. 66, KIADB Bengaluru Aerospace Park, Singahalli Village, Budigere Post, Bangalore North Taluk, Bangalore - 562 129.

T +91 99000 92569, +91 96117 63479

Email: sales.in@starrag.com | www.starrag.com



- The supplier must sign a confidentiality agreement and commit to protecting information provided by OEMs. The ITAR (International Traffic in Arms Regulations) standard may be required for military products.
- The supplier must have a qualified team providing technical support, design and specification clarification, product development, problem resolution, etc.
- The supplier must be able to process and share CAD files (computer assisted design) with OEMs based on the software they use.
- The supplier must be able to exchange data electronically. File Transfer points (FTP) are sometimes used.
- The supplier must demonstrate that it has implemented a good project management system with the OEM through the hiring of a dedicated resource (project manager) able to provide all pertinent information to the OEM and resolve problems. OEMs like being able to consult an organisation chart of people working on their projects.
- The supplier must have a production planning system (e.g. MRP or ERP) that is reliable and assures on-time deliveries. A sophisticated system is necessary if the supplier is considered critical. If not, in-house software may be considered sufficient if it is effective.
- The supplier must have a system for monitoring orders and information should be quickly and easily be available to the OEM.
- The supplier must demonstrate that it has implemented an effective supply management system. It must be able to control and guarantee the quality of products/services coming from its suppliers and subcontractors, while managing risk.
- The supplier must demonstrate that it is able to effectively measure its internal and external processes (cycle times, delivery lead times, reject rate, set-up times, etc.).
- Hold appropriate licenses and/or quality certifications recognised by an accredited organisation.

The government can play a critical role at this juncture. Select tax incentives and reforms instituted for a more favourable operating environment will go a long way to provide the necessary “pull” for aerospace manufacturing. In the defence



File picture of India's own LCA (Light Combat Aircraft) Tejas displaying low-flying aerobatic skills at Yelahanka Air Base, Bangalore. The Government is giving a strong impetus to the indigenisation process in the aerospace manufacturing sector.

Capability assessment: Indian companies				
Company	Design & Engineering	Component Manufacturing	System manufacturing	Aircraft Assembly
Aequis	√	√	X	X
Dynamic Technologies	√	√	√	X
HAL	√	√	√	√
L&T	√	X	√	X
Mahindra Aerospace	√	√	√	X
Maini Precision	√	√	X	X
Max Aerospace & Aviation Ltd	√	√	X	X
NAL	√	√	√	X
Taneja Aerospace	√	√	√	X
Tata Advanced Systems	√	√	√	X

Source: PwC Analysis

sector, the government has cleared Rs1,10,000 crore worth of defence procurements in the recent past with 90 percent under the ‘Make in India’ categorisation. This is an encouraging trend.

At the same time, there is a need to provide tax incentives to promote setting up manufacturing facilities and technology transfer to accelerate the pace of indigenisation. Besides, the ‘Make’ category has been recognised as one of the modes of capital acquisition under the Defence Procurement Procedure which include high technology complex systems or critical components/equipment for any weapon system to be designed, developed and produced indigenously.

This is also the right moment for the government to decide as to which areas/systems/technologies e.g. aero structures, engines, interiors, avionics, control systems or landing gear, Indian companies have the flair to specialise in or have the potential to be market leaders and then move on to offer incentives and subsidies. The time is ripe for Indian aerospace companies who till now have had the experience of being suppliers to Indian DPSUs like HAL and research organisations like DRDO and NAL, to start preparing themselves to be worthy partners in global aerospace supply chains. 

The author is Director – Aerospace & Defence, PwC India.

Delivering **PERFORMANCE** for Decades

With over 10,000 satisfied customers, upto 63% repeat orders and more than 30,000 running machines across the globe, the group has been delivering performance for decades.



Like us on
www.facebook.com/acemicromaticgroup



salesmmt@acemicromatic.com

THE LARGEST MACHINE TOOL GROUP IN INDIA

acemicromatic.net

Visit us at

6th IMTOS
INDIA MACHINE TOOLS SHOW

Hall - 14 Pavilion - 11



Direct Digital Manufacturing

Moving beyond prototyping, BMW is extending the application of FDM (fused deposition modeling) to other areas and functions, including direct digital manufacturing.

Rapid prototyping has become a standard practice in product development. At the BMW AG plant in Regensburg, Germany, FDM (fused deposition modeling) continues to be an important component in vehicle design prototyping. But moving beyond prototyping, BMW is extending the application of FDM to other areas and functions, including direct digital manufacturing.

The plant's department of jigs and fixtures uses a Stratasys 3D Production System to build hand-tools for automobile assembly and testing. According to engineer Günter Schmid, "BMW has determined that the FDM process can be an alternative to the conventional metal-cutting manufacturing methods like milling, turning, and boring." Schmid and fellow engineer, Ulrich Eidenschink, have shown that financial advantages include cost reductions in engineering documentation, warehousing, and manufacturing.

For hand-held devices used on the assembly line, engineers have discovered that there are even greater advantages that arise from the design freedom that FDM offers. Capitalising on the elimination of constraints, Schmid and Eidenschink employ FDM to make ergonomically designed assembly aids that perform better than conventionally made tools.

Real solution

To improve productivity, worker comfort, ease-of-use, and process repeatability, the plant uses FDM to enhance the ergonomics of its hand-held assembly devices. The freedom of design allows engineers to create configurations that improve handling, reduce weight, and improve balance. According to Schmid, "The tool designs we create often cannot be matched by machined or molded parts." In one example,

BMW reduced the weight of a device by 72 percent with a sparse-fill build technique. Replacing the solid core with internal ribs cut 1.3 kg (2.9 lbs) from the device. "This

“**FDM is taking on increasing importance as an alternative manufacturing method for components made in small numbers.**”
Günter Schmid,
Engineer, BMW



How did FDM compare to traditional CNC machining for BMW?

Method	Cost	Lead
Traditional CNC Machining (Aluminum)	\$420	18 days
Fortus System (ABS-M30 Thermoplastic)	\$176	1.5 days
Savings	\$244 (58%)	16.5 days (92%)

may not seem like much, but when a worker uses the tool hundreds of times in a shift, it makes a big difference," says Schmid.

Another advantage of direct digital manufacturing is improved functionality. Since the additive process can easily produce organic shapes that sweep and flow, the tool designers can maximize performance while improving handling characteristics. "The layered FDM manufacturing process is well suited for the production of complex bodies that, when using conventional metal-cutting processes, would be very difficult and costly to produce," says Eidenschink. An example is a tool created for attaching bumper supports, which features a convoluted tube that bends around obstructions and places fixturing magnets exactly where needed.

The jigs and fixtures department has developed a simple flow chart to determine when FDM is a fitting option. The criteria are temperature, chemical exposure, precision, and mechanical load. With Stratasys ABS material, which the engineers find comparable to polyamide (PA 6), many tools for vehicle assembly satisfy the criteria. For those that do, designers can create devices that Capitalise on all the advantages of the additive process. Both Schmid and Eidenschink believe that no enterprise can afford to do without rapid prototyping for product development. Yet, they see so much more possibility. 



Drill Ø Range
1.875" to 4.0"
(47,63mm to 101,60mm)



UP TO
4.5X
LENGTH OF CUT

Revolution Drill®

Large Diameter Drilling

- ▶ Removable cartridges for easy replacement
- ▶ Drills from solid, no pilot required
- ▶ Diameter adjustable up to 0.200" (5,1mm)
- ▶ One tool covers a range of sizes

PROTECT
YOUR INVESTMENT
REDUCE
YOUR INVENTORY



 www.alliedmachine.com / 330.343.4283



ALLIED MACHINE
& ENGINEERING CORP

Holemaking Solutions for Today's Manufacturing

Designed for the machining of complex **aerospace** components with unsurpassed efficiency



Multi-tasking machine

INTEGREX e-H SERIES



- Long boring bar, rigid tool holder system with four clamping units for enhanced machining capability.
- Large Y-axis stroke and powerful milling spindle improve machining capability and high accuracy machining.
- Large swing and Y-axis stroke for large workpieces
- Linear guides on all linear axes for increased rigidity



High-precision, High-productivity, double-column machining center

FJV-35 II SERIES

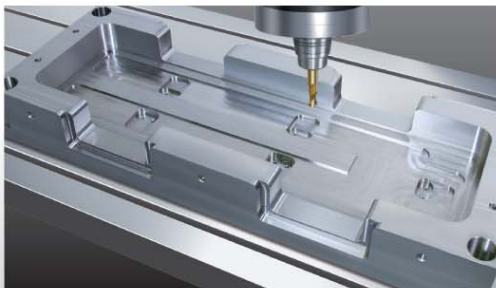

- Large variety of machine sizes available to meet the requirements of a wide range of workpiece sizes
- Multi-surface attachment (option) for higher productivity
- Large variety of available spindle specifications to meet the production requirements of virtually any workpiece material
- Non-cutting time is reduced thanks to the utilization of linear roller guides on all axes and direct servo driven ball screws





▲ Landing gear component



INTEGREX e-420H-ST



▲ Aerospace component



FJV-35/120 II

YAMAZAKI MAZAK INDIA

+ (91)-2137-668800 marketing@mazakindia.com

Your Partner for Innovation

Mazak



Technology advancement – need of the hour

Reflecting the entrepreneurial spirit of Coimbatore, Intec 2015 saw a plethora of opportunity for technology advancement, and visitors looking for solutions to help them move up the value chain.

By Shivani Mody

The industrial city of Coimbatore is highly renowned globally for its entrepreneurial spirit and technical aptitude to develop solutions even in the most challenging scenarios. This attitude of adopting technology up gradations and innovations by the industry, with an appetite of enterprise in its ethnicity, has made Coimbatore a truly global outsourcing hub.

In the backdrop of its upbeat entrepreneurial, risk-taking mindset, the sixteenth International Machine Tools & Industrial Trade Fair Coimbatore (Intec 2015) saw a series of exhibitors - both local and from across the globe, showcasing the next generation technologies and buyers with interest in technology advancement, on the same platform. Moreover, Intec 2015, held from June 5 to 9 at the Codissia trade fair complex in Coimbatore, also witnessed two concurrent events - the ToolEX 2015 and Industrial Automation Expo 2015.

The five-day exhibition – Intec 2015 was inaugurated in the presence of dignitaries Giriraj Singh, Union Minister of State for MSME, E K Ponnuswamy, President, Codissia, C



Igus stall

Muthusami, President, Tamil Nadu Small and Tiny Industries Association (TANSTIA), V Arumugam, Zonal GM, National Small Industries Corporation (NSIC), Chennai, Chandra Prakash Singh, former Chairman of the National Pharmaceu-

Exhibitor Speak

Coimbatore is an important market as it has presence of all the sectors - pumps & valves, auto, textile, general engineering, die and mold et al. As part of the event we are in touch with the local market, meet customers and understand their issues. With innovations in the machine tool industry we have designed specially targeted machines at the right price for the market.

I N Bhattacharya, Senior GM – Marketing & Sales, Lakshmi Machine Works Ltd



DANOBAT



LEADING SUPPLIER WORLDWIDE

DANOBAT, a leader in Machine-Tool technology, has been committed to the aerospace industry in designing and developing state-of-the-art solutions for critical landing gear components. DANUNI range revolutionises the machining process by rotating the complete component between centers. With DANOBAT grinding machine range HG, WT and DANUNI models, customers can obtain reduction of up to 50% in machining overhaul times due to the integration of OD and ID operations, and measuring in one machine, providing a fast R.O.I. Besides the DANOBAT B axis can provide two external and additional internal wheels in the same wheel head configuration.



A340 - MAIN LANDING GEAR (MLG)
Outer cylinder



B767 - MAIN LANDING GEAR (MLG)
Outer cylinder



B787 - MAIN LANDING GEAR (MLG)
Truck beam



A320 - NOSE LANDING GEAR (NLG)
Inner cylinder



B737NG - HANGER LINK



B737 - NOSE LANDING GEAR (NLG)
Inner cylinder

DANOBATGROUP

DANOBATGROUP India

Office No. 7, Business Avenue, 2nd floor
Niyoshi Park Road, Sanghvi Nagar, Aundh
411007 PUNE (India)

Tel.: + 91 20 66094531

Fax: + 91 20 66094531

danobatgroupindia@danobagroup.com

www.danobatgroup.com





Exhibitor Speak

This is a good platform for the Southern region and it helps us reach the local entrepreneurs. Also as Coimbatore has access to more than 50 educational institutions, we get to connect with engineering students, create awareness about the industry and encourage students to do projects in the same field.

G C Venkatesan, Executive Director, Janatics India Pvt Ltd

Coimbatore is a big market and we as part of the machine tool industry consider it important to have a regular presence at this event. The main aim is to connect with customers and discuss their pain points rather than look at business gains.

Hemant Kumar, Sr Vice President, Jyoti CNC Automation Ltd

Overall, businesses in smaller cities are now expanding. Having a presence and visibility in these markets is necessary, as we can give better solutions at competitive prices. We are also looking to break a myth that we are only a machine tool player.

Saju Abraham, Marketing Head (Machine Tools), Wendt India Ltd

We are coming to the event after many years and are showcasing a special machine specific for this market. The good customer outlook is a positive indication. Also some of the sectors where we want to grow are the pumps, manufacturing, aerospace and medical.

Rajan D, Deputy Manager Sales, Makino India Pvt Ltd

Specialized technologies such as touchscreen, SMS update, safety password for our next generation products, set us apart from competitors. These products - the cooling tower and air dryer, will give an added advantage to the MSME companies.

B Arshad Hariff, Senior Marketing Officer – South, Gem Equipments (P) Ltd

We have been part of the event since the inception as it is our hometown exhibition. The organizers have a strong entrepreneur collaboration base, which has helped in promoting our company to a wider audience and greater geographies.

Navaneeth Mysamy, Executive Administrator, MM Gears (P) Ltd

One of the main advantages of the event is that it has reached an international level but still managed to retain its South flavour. Having a stall at the event has always given us a good return on investment. We have also been able to network with international companies from Korea, Taiwan and Japan, all under one roof.

R P Devarajan, Mg Partner, Toolshoppe

tical Pricing Authority (NPPA), P N Balasubramanian, Chairman, Intec 2015 and J Balu, Vice Chairman, Intec 2015.

Technology prowess and machine display at the event included CNC machines, CNC & PLC controls, CAD/CAM systems, special purpose machines, co-ordinate measuring machines, precision tools, cutting tools, dies & molds, hydraulics/pneumatics, instrumentation & automation, machine tools and accessories, material handling systems, power tools, testing & measuring equipment, welding, textile and fabrication machinery & equipment, machineries for process industry, related IT and consultancy services, foundry and metallurgy equipment, liquid handling pumps and motors & fittings, industrial electrical and electronics, factory cleaning



Jyoti CNC stall

& pollution control equipment, industrial consumables among others.

On display, at the event, were even some of the latest robotic technologies – products that would enable the industry adopt automation and expand their business growth.

A noteworthy factor was that Intec 2015 event was able to attract international exhibitors from countries such as Germany, Japan, China, Switzerland, Singapore, Sharjah and South Korea apart from major Indian companies.

Experiencing overwhelming response from engineering companies across India and other countries, the event saw nearly 425 companies from a wide spectrum converging under one roof, networking and

TECH

MOTUL

**THE INDUSTRIAL LUBRICANTS
DIVISION OF THE**

MOTUL

GROUP

**METAL WORKING
FLUIDS**

**SPECIALTY LUBRICANTS
& GREASES**

**MAINTENANCE
LUBRICANTS**

**HIGH PRESSURE
DIE CASTING**

**QUENCHING
FLUIDS**

www.motul.com

Atlantic Lubricants & Specialities Pvt. Ltd.
301, Ketan Apts., 233, R.B. Mehta Marg
Ghatkopar East, Mumbai 400 077
Tel: + 91 22 2501 1960/2501 1961
Fax: + 91 22 2501 1928

Motul
119, boulevard Félix Faure
93300 Aubervilliers - France
Tél.: +33.1.48.11.70.30
Fax.: +33.1.48.11.70.38



Exhibitor Speak

Being part of the event since many years, we see this as a great platform to meet decision makers from various sectors such as manufacturing, pharma, consultants etc. We also get to showcase our innovative designs for high speed doors, rolling shutter, dock leveler, dock shelter, motorized gates among others.

Samir Gandhi, Director, Gandhi Automations Pvt Ltd

All companies need automation and we implement open automation systems based on PC control technology. This is a great advantage for companies as they can use their ideas and implement the system, which comes at a reduced price point. Also the event gives an opportunity to interact with engineering students and explain our technology first-hand.

Ajey Phatak, Marketing Manager, Beckhoff Automation Pvt Ltd

The event has helped us create brand awareness for our company and products. Many people are aware of us and we have had potential visitors. One of our new products for this market is the round tester and people are seeing value in the product.

M Ramesh Kannan, Assistant Manager – Sales, Mitutoyo South Asia Pvt Ltd

Other than having a good customer base in South India we have introduced new products for the region. The new drilling machine attachment and beveling machine have potential in this market. Customers will see increased productivity when using our new products.

Ramesh Magadum, Sales Manager & Automation Expert, Suhner India Pvt Ltd

We have dominantly been in the steel, wind energy industries naming a few, but now we plan to grow in the machine tool industry. Over the years we have grown to offer end-to-end gear work and now we provide one of the widest offerings of refurbishing options available for bearings and related equipment.

Aniket Joshi, Manager – NBD & Strategy, Timken India Ltd

Being part of the event is mostly a brand building and awareness generating activity. We are here to speak about our newly opened factory in the area and also showcase our new machines. Also part of our display is a software that is new in the market.

S S Karthik, Manager-Business Development, S & T Engineers Pvt Ltd

Our main focus is the oil and petrochemical sector. Since the sector is not upbeat currently we are utilizing this time for our branding activity. Nowadays, we see more need for specialized machines since the tooling; machine structure is undergoing a change. Moreover, customers are more focused on quality.

Abhijeet Asre, Product Manager, Electronica Hitech Machine Tools Pvt Ltd

exploring business opportunities.

As a value-add to the exhibition, organiser Coimbatore district small industries association or Codissia along with its conference partner, Texas Ventures, organised a conference – CEO's Conclave on Global Manufacturing Cluster Vision "GMCV 2020" on 5 June, wherein a group of top CEOs from the industry, took part in a panel discussion related to various relevant topics facing the industry. As part of his address, Aravind Bharadwaj, Senior VP - Advanced Technology & Services, Automotive & Farm Equipment Sectors of M&M Ltd said that MSMEs needed to register new product ideas or manufacturing processes and look at developing them to generate revenue. Bharadwaj is also of the view that auto component vendors in



LMW stall

Coimbatore need to tap the opportunity available in the aerospace sector.

The other icing on the cake was that NSIC and SIDBI generously subsidized the participation charges for MSME units taking part in the exhibition. Also the success of the 16th edition of Intec is further established as it saw more than 70 percent returning exhibitors participating in the event. Considered as one of the important shows in South India, Intec 2015, along with the ToolEX 2015 and Industrial Automation Expo 2015, delivered its promise of latest technology and business enhancement.

From the organisers

As organisers of Intec 2015, Coimbatore

Our Lean Selection cam reflects our own core values.
Precision, reliability, high performance.



HIGHSPEED

JUNKER Lean Selection cam High-performance non-circular grinding.

The Lean Selection cam is an **economical and flexible** machine concept for **grinding camshafts in any lot size**. The wheel-head can be equipped with up to **two high-capacity grinding spindles**. The **swiveling B-axis** manages rough and finish grinding or the grinding of bearings and cam lobes in a single clamping.

The Lean Selection cam CBN grinding machine combines **simplicity in operation**, precision and lowest total cost of ownership.

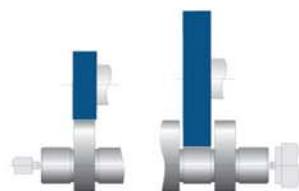

Possible cam profiles



Concave cam profile



Tangential cam profile



Elliptical cam profile



Polygonal cam profile



Erwin Junker Maschinenfabrik GmbH
India Branch Office
Office No. 104, City Square
29-2, K.M. Gandhi Path, Bhamburda
Shivaji Nagar, Pune 411 005

Phone: 020 255 338 96
E-Mail: info@junker.in
www.junker.in





Exhibitor Speak

As businesses in this region have started growing it is important for us to have a presence at the event. The platform has helped us create awareness regarding our brand. People have also enquired for our agency, which is a positive sign.

Rajib Ghosh Roy, CEO, Hittco Tools Ltd

The event is a platform for us to create awareness related to our new products. One of our new products is a drill for the DIY home segment, which is growing in the country. We also have a product for steel manufacturers, where the teeth design gives better finish to the end product.

L R Raj Prabakar, Head – Product Development, Addison & Co Ltd

Our premium efficiency motors will be useful for the industries in this area. Features such as reduced noise/vibration levels, inverter grade winding, six lead terminal box, dual mounting hole and reduced life cycle cost will be beneficial for customers. Also it has a low pay back period.

D K Sinha, DGM, Motor Marketing, Bharat Bijlee Ltd

The event is important from the point of view of new business development. Since business is growing in this market, it will give us an impetus to showcase our new products. Whenever customers expand their business we want to provide them a viable option with our products.

William Lin, Deputy General Manager (2nd business dept), Hiwin Technologies Corp

This is our first time at the event and we have had potential enquiries. Some well known firms have asked us for samples as the first step. Our bearings were mostly used in the agriculture industry but with this event we have entered into auto and other industrial sectors.

Santosh Tiwari, Asst Manager – Mktg, ARB Bearings Ltd

Coimbatore is a manufacturing hub for the pump and valve industry and we have specific solutions for this sector. Potential customers came to our stall with specific requirements. Our job has been mainly to educate visitors about our solutions and show its benefits.

Raman Baskaran, Account Manager, Faro Business Technologies India Pvt Ltd

We have a strong customer base in the city and hence it is necessary for us to be present here and display the strength of our infrastructure. The event is a single point of contact to meet all customers at the same time, in one location.

V Giritharan, Area Manager, Hexagon Metrology (India) Pvt Ltd

district small industries association (Codissia) now has a membership of more than 5,200 members, up from about 40 members in their founding year 1969. The association works for the growth and prosperity of industries and has made significant contribution towards building Coimbatore as a strong and stable industrial city.

Codissia also focuses on development conducting series of seminars, training programs, exhibitions, industrial trade fairs and industrial visits. "Being organised by potential buyers, Intec is the only engineering fair in India where sellers get to meet the buying decision makers right away unlike other fairs. In addition, the industries of this region are ever willing to adopt new technology, which also is a catalyst for manufacturers to offer custom-



Makino stall

ised solutions suited to their needs. This is the reason why Intec continues to remain popular edition after edition," says P N Balasubramanian, Chairman, Intec.

"Trade fairs and exhibitions play a vital role for continuous technology upgradation for the growth of industry and to improve the economy. This is an ideal opportunity to get an insight into the dynamic global industrial scenario and new technologies, which are cornerstones of development. At Intec 2015 we left no stone unturned to ensure that participants get full opportunity to display their technological advancement, innovations and modernisation to the discerning industrial fraternity of this region," adds E K Ponnuswamy, President, Codissia. 

OMRON

Transforming Packaging Industries through automation



Vision System



HMI



Machine Automation
Controller



Servo Motor



Proximity sensor



VFD



Encoder

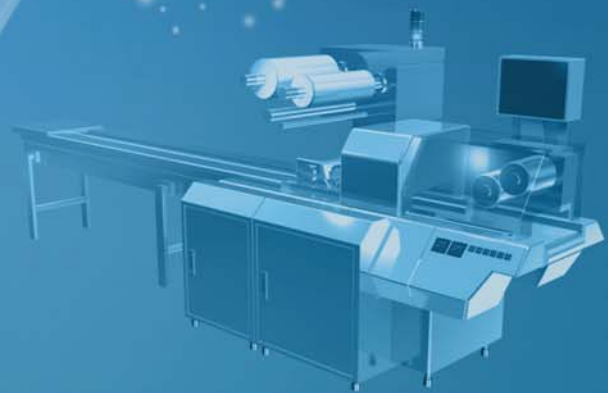

In Packaging Industries when reliability is asked for, from start to finish from initial requirement to on-site support or zero defects Omron ensure that it applies to everything it does. Omron focuses only on Quality, thus ensuring that it's know-how is beneficial to the end user. These are the principles that derive the expertise in transforming a mundane caterpillar like machine into a flawless butterfly.

www.omron-ap.co.in

realizing



New frontiers

The machine tool industry can surely contribute to the defence sector in a big way, says **Ravi Raghavan**, CEO, Bharat Fritz Werner Ltd



Q What importance does Intec hold for BFW and how has it grown over the years?

Our customers in Coimbatore use each and every feature of the machine so being here helps us generate ideas, get valuable feedback and suggestions. This time at Intec we showcased only our turning solutions named – ‘Simply Turn to BFW,’ and displayed the standard and the high-end machines.

Q The Indian machine tool industry is now foraying into the defence sector. What are some of the challenges for the industry in this context?

A major opportunity for the government is to make local machines for defence equipment rather than depend on foreign equipment. The industry is capable of making sophisticated machines but it lacks the user knowledge.

To solve this issue, the government can work with identified machine tool builders and other stakeholders while encouraging knowledge sharing for a stipulated time and then build the desired machines.

Q What are some of the growth strategies of BFW?

For our way forward we look at three strategies – widening our product portfolio, second is widening our applications for various industries and the third is spreading across more geographies.

The next level

To compete in the international market, Indian machine tool industry has to focus on improving productivity and quality, says



Indradev Babu, MD, UCAM Pvt Ltd

Q What are your plans for the company?

We have many products such as the torque motors, gear hobbing machines, high quality bearings, positioning systems but our main focus continues to be the CNC rotary indexing tables. We are now foraying into aerospace and defence sectors, not just in supplying rotary tables but giving complete solutions.

Q Coimbatore MSME units are looking to make in-roads in the defence sector. What are some of the challenges these MSMEs face?

MSMEs need to understand that the defence sector looks for people who have technology, necessary certifications and competence. Also MSMEs will need the right professional advice to know where the products can be a perfect fit and how to bid in a tender-driven process. Further, the government has certain conditions like the payment terms, which are not typically friendly for MSME units.



I would suggest for the MSMEs to find out their own strengths, develop technologies and then target opportunities in the defence sector.

Q What will be some of the prominent technology trends that Indian companies will need to address?

In general, to compete in the international market, Indian machine tool industry has to focus on improving productivity and quality. Also there is a shift towards aesthetics and even internal parts have to be appealing with proper colour schemes. This is one issue that Indian companies have not been able address satisfactorily.

Some of the other issues are user-friendliness, and ease of use of instruments. Also use of software and panels with touchscreens are fast becoming a norm.

By Shivani Mody

Panasonic

**For machines built for speed and style,
equipment that keeps pace.**



Panasonic ToughBooks & ToughPads are mission critical devices that perform at your workplace, wherever it may be.

Grime, grease, new gen technology... Panasonic ToughBooks & ToughPads help drive efficiency and productivity in field applications with challenging environments. Loaded with the latest innovative technologies these extreme machines are built to never fail you – come what may.



CF 19



CF 31



FZ G1



FZ B2



Performance



Ruggedness



Mobility



3G Solution



IP65



Customisable

TOUGHPAD

TOUGHBOOK

Find us on:



Contact us: 1800 103 1333 | Website: in.panasonic Toughbook.asia E-mail: toughbook.marketing@in.panasonic.com



Connecting with Coimbatore



When latest technology comes into a local show such as Intec it is indicative of acceptance of new technology, says **T K Ramesh, CEO, Micromatic Machine Tools Pvt Ltd**

What are the key takeaways from Intec 2015?

From a participation perspective it is good and the seriousness of the local market is clearly visible. We see lot of newer machines, increased and intense competition, and certainly technology up-gradation of domestic manufacturers is seeing a rise.

When latest technology comes into a local show such as Intec it is indicative of acceptance of new technology. In a regional show



consumers dominantly indicate what they are capable of consuming and this has gone up a notch compared to earlier shows.

What are the technology requirements of the local industry?

A diverse market, not influenced by the automotive sector, Coimbatore consists of majorly entrepreneurs who are adventurous. Since people availability is limited, automation solutions or robotic applications will tend to see greater adoption in this region. Overall the city has an ability to digest higher technology and there is a premium sector, which is ready for automation and high-end solutions.

What is the importance of having a presence at Intec?

Intec is now a well-known brand and we have been part of it since the start. The event is more of a platform for us to reconnect with our customers and also meet and speak to the local entrepreneurs who prefer to attend only the Intec exhibition.

Widening horizons

The MSMEs of Coimbatore are looking to tap opportunities from the defence and aerospace sectors, given their experience of providing solutions for the automotive and other diverse industries.

With regards to their foray into aerospace and defence sectors, the MSMEs of Coimbatore have requested for government support in terms of policy changes, payment terms to name a few. "The department is working on simplifying rules that are restricting the growth of MSMEs," said Giriraj Singh, Union Minister of State for MSME, at the inauguration of Intec 2015 exhibition.

Additionally, the MSMEs were ready to form a consortium to bid for defence procurement orders said Coimbatore district small industries association - Codissia, the organisers of the exhibition. The collective effort will allow the industry to develop and supply sophisticated, high technology precision engineering products, to meet the criteria and product guidelines of the defense sector. Collaboratively the consortium would also address challenges such as payment terms, on-time delivery, and capital investments effectively, they said.

Over the years, the MSMEs in Coimbatore have worked with international car-makers and their high quality of manufacturing is recognized at the global level. This has further given confidence to suppliers and component vendors in Coimbatore to consider foraying into the aerospace industries.

Moreover, the adventurous, entrepreneurial attitude of the Coimbatore industry allows them to quickly adopt next generation technology, enabling them to provide solutions for the defence and aerospace sectors.

Also industry experts such as Aravind Bharadwaj, Senior VP - Advanced Technology & Services, Automotive & Farm Equipment Sectors of M&M Ltd, have urged the auto component vendors in Coimbatore to get into the aerospace sector and that it promises a good future.

V Sundaram, Vice-President, Codissia said that the Coimbatore industries were more into manufacture of 'high technology precision components' and the aerospace industry was looking for competent suppliers in this sphere.

By Shivani Mody

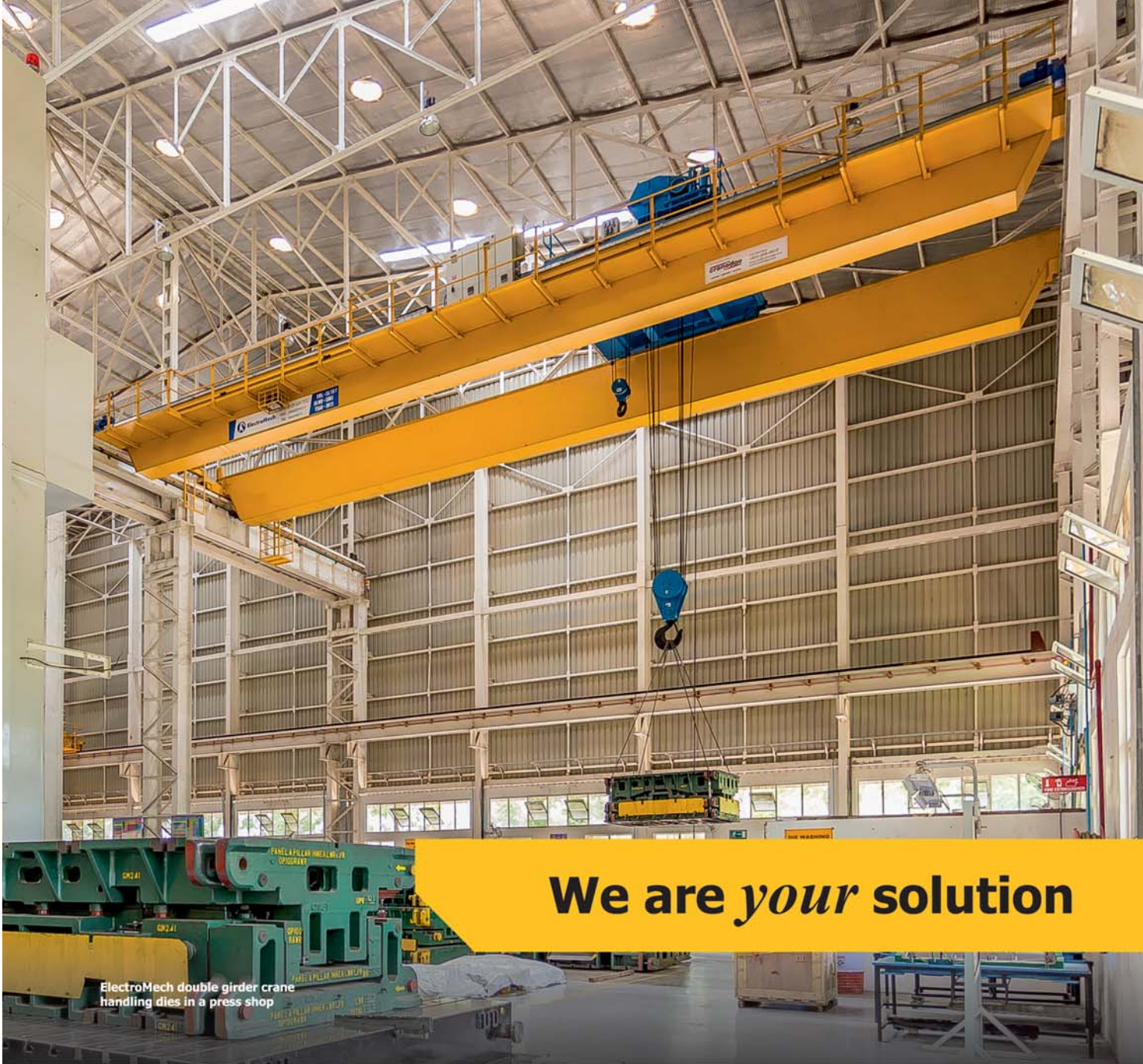

ElectroMech double girder crane handling dies in a press shop

We are *your* solution

Customised crane solutions for integration of handling in your plant

In an automobile plant, handling needs are demanding. Unwieldy and heavy components, pressed parts, dies, moulds, chassis and auto bodies need to be handled through several stages. Well engineered handling systems which can integrate operations, determine the productivity of a plant.

Yes, find an ingenious customised crane solution from us - for every requirement. Reliable and safe, with assured performance round the clock. No wonder, we are your preferred solutions partner - every time, anywhere in the world.



Ensuring optimum performance

The right metal working fluid can help the user to increase productivity, says **Hugh Dowding**, Board of Director – Motul SA, France / Director & Head – MotulTech

By Niranjan Mudholkar

Q Manufacturers are concerned about increasing their machine performance and productivity without compromising on safety and environment regulations. What role is MotulTech playing in this?

Innovations in lubricants, especially in metal working, are less driven by the desire to improve productivity and more by regulatory constraints. The rise of REACH in Europe, GHS in terms of labelling of products and different chemical inventories country by country are the major determining factors. These factors have stultified innovation by chemistry creators.

However, the need to re-formulate products as a result always gives opportunities. High performance metalworking fluids that are free from chlorine and sulphur with extremely low foaming tendency are the goals. Combine this with low staining on even the most exotic alloys and you arrive at the product desired by most advanced users. In the field of associated lubricants, technologies such as fast separating slideway oils, super clean hydraulic fluids and synthetic gear and compressor lubricants all play their part in extending the life of

fluids and lowering total operating costs.

MotulTech offers a huge range of products with different combinations of high performance as well as with compliance with strictest environment regulations. This range not only covers the metal working field but also encompasses the high performance industrial lubricants for very severe working conditions of steel or cement manufacturing or mining or food grade lubricants for different industries.

Q The environmental and safety concern associated with the use of metal-cutting fluids is a major issue today – particularly with regards to disposal of used oil. Tell us what is your organisation doing in this context?

The European Waste Framework Directive is useful in making people clearly understand the priorities, with re-use or continued use being number one and disposal the last resort.

We are working towards improved efficiency by extending the life of the fluid and tooling without compromising on the effectiveness. We as professional suppliers understand how to assist our customers with this. Ultimately, when fluids need to be disposed of, they should be re-cycled/re-refined if based on mineral oil. In the case of water based fluids, the ultimate disposal is minimised by techniques such as evaporation or Reverse Osmosis.

Q One aspect with regards to energy efficiency (which is usually overlooked in manufacturing plants) is the technology behind the lubricant used. Using energy efficient lubricants can actually enable manufacturing facilities to operate at maximum efficiency with optimal cost. How is MotulTech helping its customers here?

Yes, many overlook this aspect of lubricants. Lubricants not only help in improvement of machinery by way of reduction in downtime by less stoppage and reduction in frequency of lubrication but can also offer great saving in energy consumption by selection of the right product. For example, of a most common product which is hydraulic oil, if we use the hydraulic oil of viscosity index (VI) 96 and 150, the viscosity of both the oil is 68cst at 40 deg centigrade it will increase to 1060cst for oil with VI of 96 and 648cst for oil with VI 150 at Zero degree centigrade. Now you can understand that how much of extra energy you need to pump the oil with such a huge viscosity.

We at MotulTech are offering this type of product with high viscosity index to help our customers not only on energy



Technologies such as fast separating slideway oils, super clean hydraulic fluids and synthetic gear and compressor lubricants all play their part in extending the life of fluids and lowering total operating costs."

Visit

Organizer



Indian Machine Tool
Manufacturers' Association



DELHI

TM

**MACHINE
TOOL EXPO**

2015

20 - 23 AUGUST

Pragati Maidan, New Delhi

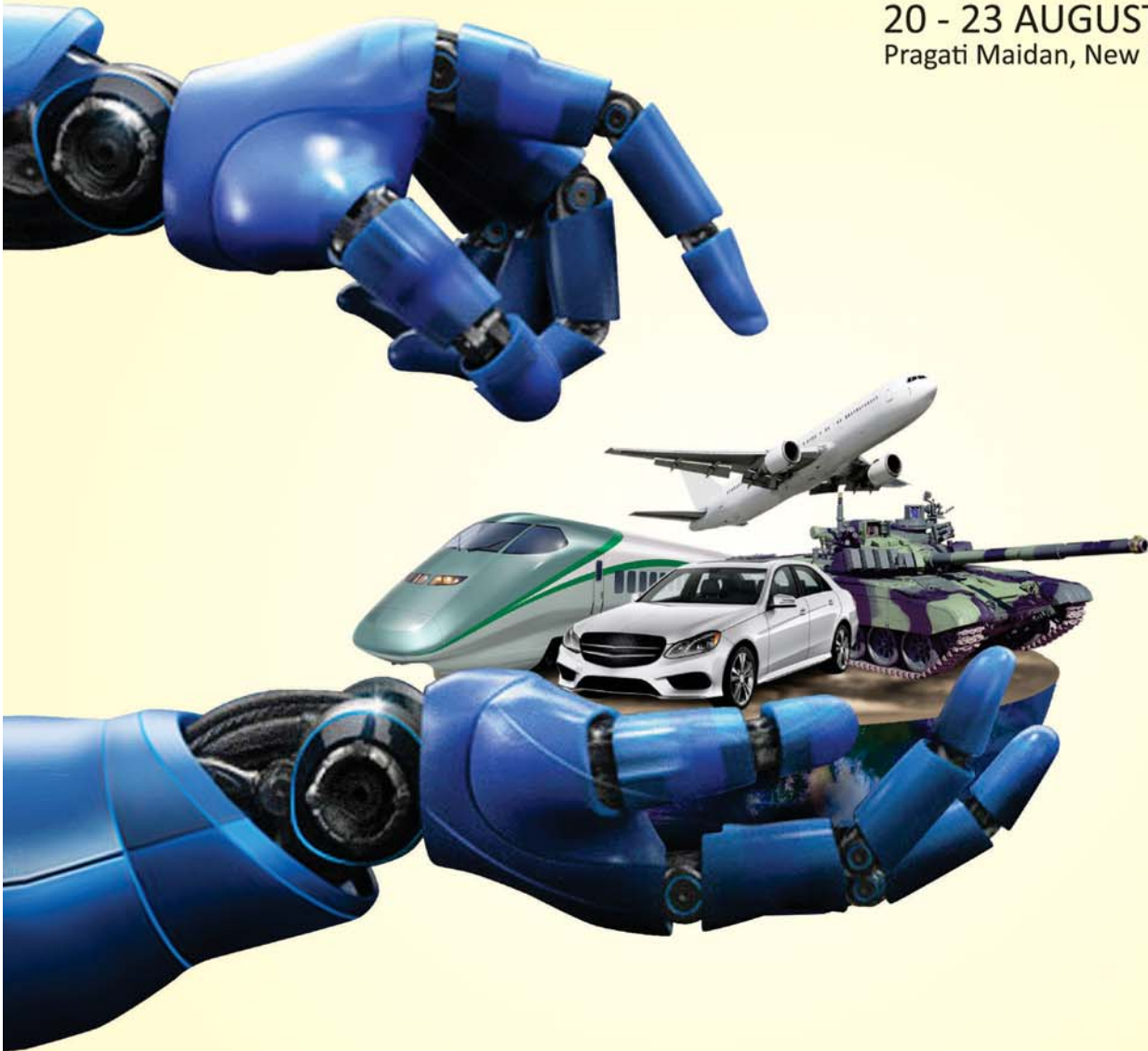

Empower Manufacturing

Experience **Delhi Machine Tool Expo 2015**

Delivered by the organizer of



Supported by



Register online, today!

www.mtx.co.in



savings but also in increasing the life of these oils by using latest technology products. We could evidence similar situations in our other ranges of products such as Turbine, Gear and Compressor lubricants

Q With growing demand for better performance from their products, manufacturing companies are increasingly relying on more and more difficult to machine workpiece materials. How does it impact your role?

In a more conventional sense the use of composites, high strength steels, structural cast aluminium parts and magnesium alloys are changing the requirements for metalworking fluids.

All this has a great impact on development of our products. We need to keep the product performing with these new developed work piece materials without any deviation from the health and safety and legal requirements.

Q Besides lubrication and cooling, fluids also have another critical function in proper removal of chips. Tell us about this in the context of your products.

True, the three functions of the metal working fluids are lubrication, cooling and flushing of chips. Flushing becomes the most critical in grinding operations. Hence it is important to select the right product considering the work piece material, operations to be done and quality parameters of the work piece. An understanding of Surface Tension in this context is invaluable.

Since you are asking about flushing, I would like to share the Minimum Quantity Lubrication (MQL) technology which is being used by few large automotive OEMs for various machining operations globally as well as in India. The MQL does not perform flushing actions and hence you need special design of machines and tools to use this technology. And we also have worked a lot to develop the special products for MQL where the emphasis is the precise amount of lubricant at the right place in the operation

Q Handling tool wear is key to metal cutting performance and overall production efficiency. How to get this right?

The tool is cutting the working piece hence handling the most difficult working conditions. Whether it is tool manufacturer, or metal working fluid manufacturer or user, everybody has a big question "How to make to the tool run for longest possible period?" Because the lower the tool life the lower the productivity of the machine. To get the optimum life of the tool it is necessary to optimise all three work in terms of the right tool, the right cutting parameters and, of course, the right metal working fluid.

A metal working fluid can have a huge impact on the life of the tool and hence help the user to increase productivity and the help to achieve the critical quality parameters of the work piece.

Q Do you work with machine tool and cutting tool manufacturers as well as end-users to provide customised and better solutions?

Yes, we are working with few machine tool manufacturers to offer them the high performance products and help them to achieve the optimum performance from their machines.

In the area of High Pressure Aluminium Die-Casting MotulTech Baraldi goes as far as championing the cause of efficiency by providing the monitoring equipment and software and ensuring the user optimises the efficiency of the die-casting process.

“
The three functions
of the metal working
fluids are lubrication,
cooling and flushing
of chips.”

Q Your expectations from the Indian market in 2015?

India is a vibrant and growing market with increased technology and professionalism year on year; the influx of global players into the market both signifies this and contributes to the improvements.

MotulTech already has a top class Team of professionals recruited from a variety of impressive backgrounds and supported by local manufacture and technical service.

The search is always on for professional Distributors and the opportunity to work with end-users to improve processes.

The business grew dramatically in 2014 and is on track to mirror that growth in 2015. Success is never guaranteed but is within reach! 



GEN. NEXT PRODUCTS FOR MACHINING

From the Grinding Fluid Specialist



*We Value your Fluid...
Every Drop is
Worth it...*



**WATER SOLUBLE -
Aluminium Machining**

CUMICUT 1013

- * Specially Designed for Aluminium Machining
- * Excellent lubricity - No Built up edge
- * Ideal for large central systems
- * Superior additive package for long life

**WATER SOLUBLE -
General Machining**

CUMI MACRO E513

- * Nitrite Free
- * Stain free parts
- * Suitable for Steel and Aluminium
- * No foam / odour

**WATER SOLUBLE
NEAT OILS**

**RUST PREVENTIVES
CLEANERS**

**FORMING FLUIDS
EQUIPMENTS**

CARBORUNDUM UNIVERSAL LIMITED

3rd Floor Parry House , 43 Moore Street , Chennai 600001.

Phone : +91 44 3000 6161 / Fax: +91 44 3000 6191.

website : www.cumiabrasives.com

For more info / demo please write to : sales_abrasives@cumi.murugappa.com





Make it Better in India

Companies that take advantage of an integrated ERP solution over the next couple of years, stand a higher chance of emerging as a Make in India champion, than those that stick with traditional systems.

By Anish Kanaran

Since Prime Minister Narendra Modi unleashed the “Make in India” initiative in September last year, the Indian industry has been abuzz with manufacturing activity. As a result of Make in India, the country is being projected as one of the most attractive destinations to set up a manufacturing business, in the world. In fact, it is reported that the government has ambitions to locally manufacture 181 products that it currently imports.

Manufacturing in India currently contributes 16 per cent of the country’s GDP but under Make in India, this is planned to increase to 25 per cent by 2022. This initiative also aims to put India into the top 50 in the World Bank’s ease-of-doing-business index (it had slipped to 142nd in 2014). With the potential to create over 10 million jobs per year for at least the next decade, it is understandable that Make in India is viewed as one of the key pillars of India’s growth story.

However, for India to realise its potential, domestic and multinational companies operating in the country must streamline their operations and become more competitive. Among the key factors for success will be how manufacturing companies reengineer their processes and use technology to improve operational efficiency, quality and workforce productivity.

Against this backdrop of rapid growth and the need to optimise performance, the Indian manufacturing sector is experiencing a data explosion. When manufacturing a product — be it an automobile, an electronic device, pharmaceutical intermediaries or fast-moving consumer goods — the amount of data is not only increasing but also becoming more dynamic. As a result, the manufacturing sector alone generates around two billion gigabytes of data each year, all of which needs to be processed, analysed and used by businesses to improve production methods, lead times and distribution. This trend is set to continue. The first self-driving cars, for example, are predicted to generate as much as one gigabyte of data per

second, all of which will be used to improve and refine the product.

The role of modern technology assumes a heightened significance for Indian businesses when we consider the explosion of data, twinned with the growth of the manufacturing sector itself.

Today, customers and businesses are consuming and sharing information quicker than ever before. Social media, mobility, analytics and cloud computing (SMAC) are becoming all-pervasive. Essentially, this means it is no longer possible or desirable for manufacturers to keep information in different “silos.” Organisations can no longer take a “make do” approach or retrofit their old-fashioned, traditional systems to meet the emerging needs. Instead, they require a system that can integrate different processes and support business automation and the decision making process.

It’s clear that as different projects and schemes under Make in India are rolled out, companies wanting to leverage new manufacturing opportunities or boost existing ones will need to become more technology-driven. ERP (enterprise resource planning) is well placed to help solve this challenge, setting some businesses apart.

Traditionally ERP was considered to be the engine of the business, but with processes adapting and changing so quickly, ERP now has an opportunity to become the controls and dashboard as well as the engine. To do that well, businesses need to select an intuitive ERP solution — one that can provide the intelligence to support better and more effective decision-making and not just supply executional data.

Companies that take advantage of an integrated ERP solution over the next couple of years, stand a higher chance of emerging as a Make in India champion, than those that stick with traditional systems. 

The author is Channel Director for Epicor in the Middle East, Africa & India.

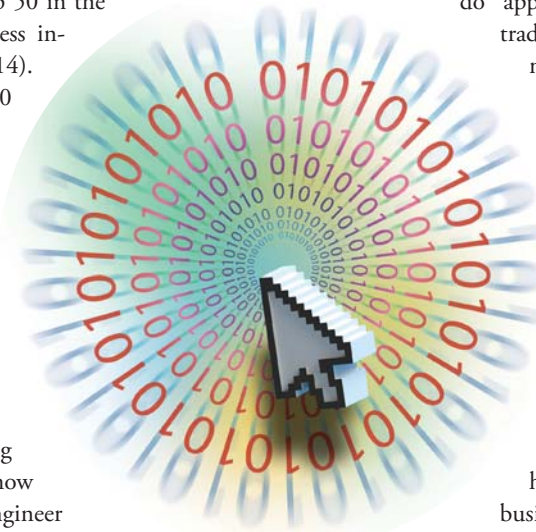

PMT Machines Limited

• Pune • Halol

CUSTOMISED SOLUTIONS

CELEBRATING 50 YEARS

CNC Turning



SC-8K
GANTRY LOADER



SC-14
BIG BORE LATHE



SC-25
CNC HEAVY DUTY LATHE

CNC Internal Grinding

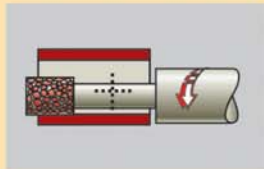

FIG-200 SPL CNC
BIG BORE GRINDER



FIGT-300 CNC
FOUR STATION TURRET



FIGE-150 CNC
ID / OD GRINDER

CNC Cylindrical Grinding

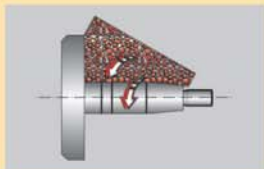

AWH-1500 CNC
LONG SHAFT GRINDER



AWH-2000 CNC
HEAVY DUTY GRINDER



SWH-400 CNC
AUTO LOADING

Surface Grinding

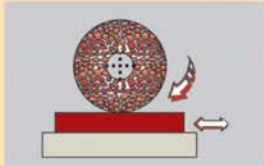

SG-106 CNC
CREEP FEED GRINDER



SGR-60
ROTARY GRINDER



SG-63
HYDRAULIC / PLC

Automats



A15/25



TD36
AUTOLOADING



A42/60

Vertical Turning Lathe

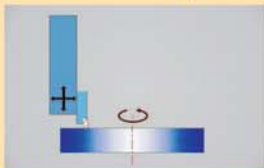

VIG-500 CNC
VERTICAL INTERNAL GRINDING



VC - 60C
1.5 M



VC - 75C
TURNMILL (2.5 M)

Built To Last

Pune : Tel : +91-20-27426219 to 23 • Fax : +91-20-27426231/35 • E-mail : rd@pmtmachines.com, marketing@pmtmachines.com

Halol : Tel : +91-2676-246786/87 • Fax : +91-2676-246788 • E-mail : cb@pmtmachines.com, mkt.brd@pmtmachines.com • website: www.pmtmachines.com

Pune : 9960693354; Mumbai : 9821713400; Delhi : 9810401815; Bangalore : 9845026905; Chennai : 9840896822; Coimbatore : 9840366822; Jamshedpur : 9934119234; Vadodara : 9662503927

Dirty machines can affect your shop floor productivity and your image

Machining of Cast Iron, is a tricky and demanding process. Inherent composition and properties of the metal pose stiff challenge to even the experienced machinist. The fine graphite residues generated during the machining process tend to stick on to the machine parts rendering it with an unenviable look.

If unattended, these impurities tend to form a thin oxidized film on surface of the machine parts. Chances of rust formation also cannot be ruled out. These can not only lead to choking of pipelines and nozzles but also significant reduction of machine lifetime. Dirt on the machines is not only a blot to your reputation but can also impede efficiencies. While chances of tool breakage and poor finish increase, the biggest impact is on the morale of the operator!

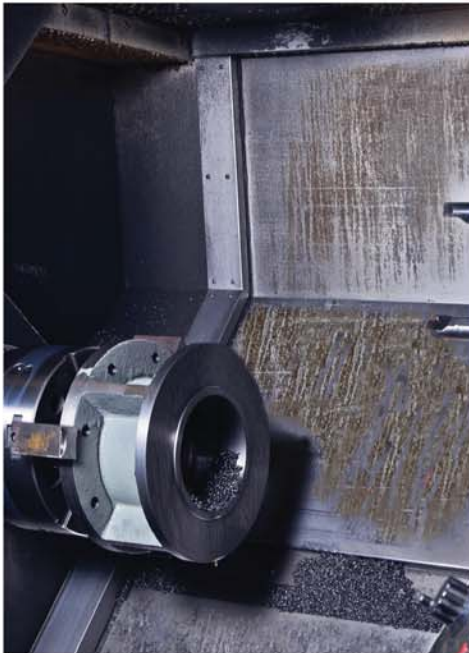

Scale formation with ordinary cutting fluid

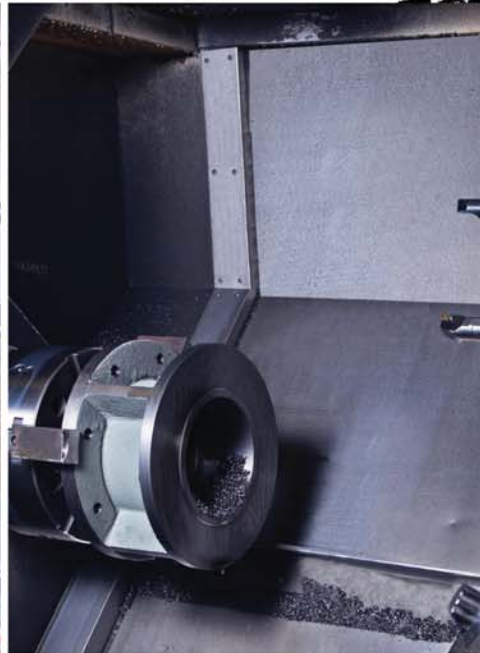

Machine after switching over to Avantin

Cutting oils • Deep drilling oils • Cleaning fluids • Wire drawing fluids
• Forging oils • Tube drawing fluids

Don't be surprised if the operator starts complaining about skin irritation and foul smell. With tempers running high and production targets to be met, this certainly is an undesirable situation.

What you need is a dependable metal cutting fluid. Like Avantin from BECHEM. An unbeatable range of synthetic and semi synthetic based cutting fluids for regular to even the severest of the machining processes.

Dirt on the machine or a blemish on your image?

BECHEM's Avantin range of metal cutting fluids are developed with special formulations with superior flushing and detergent properties that ensure less stickiness thereby a stain free and sparkling machine.

Apart from low consumption and increased sump life, the Avantin range also provides excellent corrosion protection to machines and components.

Get in touch with BECHEM's well-trained Service Engineers who work systematically to ensure that you stay focused on surpassing production targets than being bothered about coolant issues.

Choose a cutting fluid that takes care of your reputation, switch to Avantin.

CARL BECHEM LUBRICANTS (INDIA) PVT LTD
28D, Bidadi Industrial Area, Bidadi - Harohalli Road, Bangalore 562109
Ph: +91 80 669 00 800/01/02. Fax: +91 80 669 00 803
www.bechemindia.com
Mail to info@bechemindia.com



BECHEM
LUBRICATION
TECHNOLOGY



Passion and precision

It is the versatility, convenience and speed of operation that initially stood as a backbone for lasers. Eventually, with tremendous improvements, precision, quality of finish and low cost of operation joined the list, says Maulik Patel, Executive Director

By Niranjan Mudholkar

Sahajanand Laser Technology Limited started its journey in 1992. How has it evolved since then?

The first building block of the company was the manufacturing of Laser diamond processing system. With funds accumulated through known sources and knowledge gained from previous work experience, we designed and developed an application for laser that could help in processing diamond jewellery. We were successful in commercialising our first working model in a month's time. The machine could process thrice as much of diamonds processed manually. The investors were very happy seeing the machine's productivity and quick ROI. This is how our journey in building Laser processing systems began.

Today, Sahajanand Laser Technology Ltd (SLTL) is an Indian multinational company offering wide range of laser equipment catering to various industry segments. Perhaps, it is the largest laser systems manufacturing company in India. Since the inception of the business, SLTL has developed and commercialised more than 40 laser solutions and have crossed 7,000 installations in more than 22 countries across the globe.

The key to our success is the persistence we've got on Research and Product development. R&D is a part of culture at SLTL. We have been consistent in providing advance and convenient laser system for varied industry requirements. We have evolved ourselves from providing standardised solutions to providers of customised turnkey projects involving lasers. We have clientele in all major industry segments. Whether it's a multinational company or a small job work center, we have a best solution to satisfy their requirements.

Our products have gained hi-profile credentials. Our machines and facilities have played an important role in developing few of ISRO's Mars Orbital Mission and other satellites.



Tell us about your manufacturing and R&D capabilities.

With global operations heading from Gandhinagar, Gujarat, we have three production facilities manufacturing laser systems for industrial, gems & jewellery, medical, research and defence. We have dedicated state of the art production lines for laser diamond processing systems, laser micro machining systems, laser material processing and automation systems, industrial high-power laser systems and a separate unit for the RF & MW structures and components.

Our major manufacturing facility in Gandhinagar is the largest in India to manufacture laser equipment. We have our domestic regional offices at Delhi, Mumbai, Ahmedabad and Surat. Our overseas operations include job work center at China, and regional offices at UK, USA and Germany. Entire operations of SLTL is been executed by a work force of 600 employees including laser experts, doctorates, management professionals and engineers.

SLTL has government approved research facilities. We have a team of technocrats involved in developing new applications and solutions. At Gandhinagar, we have research facilities for industrial lasers and RF & Microwave products.



“The level of processing done with lasers is best. The smooth and fine finish acquired through lasers needs no post processing.”

Maulik Patel, Executive Director

Your Partner in the Automotive Industry



TYROLIT in India | +91 80 23121811 | sales-metalprecision@tyrolit.co.in

A Company of the SWAROVSKI Group
www.tyrolit.com

TYROLIT



Q What are the key industry sectors that you cater to?

Automobile, electronics, packaging, defence, surgical tools & accessories and jewellery are the key manufacturing segments we cater to. Lasers have a wide spectrum of applications ranging from micro machining to cutting.

Automobile: Laser marking plays a vital role in automobile industry. Catering to the requirement of product traceability, Laser marking on any automobile component has become inevitable in the production and packaging process. Laser cutting and welding are other applications that are gaining importance in Indian Automobile industry.

Serial introduction of laser integrated solutions

- India's first laser system for diamond processing application 1992
- World's first Fibre laser marking machine 2003
- World's first Fibre laser cutting machine 2005
- World's first Fibre laser cutting machine with Linear Drive 2007



Electronics: Laser Marking and Laser Micromachining has a critical role in electronics manufacturing. Lasers' precision used in PCBs, ICs, PV modules and Displays.

Jewellery: Laser marking has a major role to play in trading finished jewellery. The statutory and traceability criterion makes laser marking inevitable. Recently, customised pendants are made through Laser cutting.

Medical: Ortho implants too need traceability; hence require lasers for marking. Lasers also play a vital role in making the Cardiac Stents.

Q Energy efficiency and light-weighting are the two key focus areas of the automotive sector. How does laser technology help on these two fronts?

To meet the manufacturing trend across the world, SLTL has developed and fine-tuned its fibre laser machines to cut, weld and process various alloys. This serves best to automobile and aerospace industries that rely on such alloys for their light weight and rigidity.

Fibre laser works best on alloy metals and their applications in automotive sector includes cladding, hardening, surface polishing, marking, welding, cutting, drilling, and few others.

The other key focus aspect here in this industry is the cost

efficient operation. Involving lasers in these processes would drastically reduce the processing time as the need for post processing is eliminated most of the time. Also, the latest fibre lasers are much power efficient hence results in a relatively high savings in the electricity bill.

Q How would you describe the acceptance and usage of laser technology compared to the conventional solutions in India? What are the differentiating factors that make laser technology a better option?

Since the early 2000s, acceptance of lasers for industrial applications started increasing. With the wide spectrum of suitable applications, lasers started gaining attention from all medium and large scale manufactures. It is the versatility, convenience and speed of operation that initially stood as a back bone for lasers. Eventually, with tremendous improvements, precision, quality of finish and low cost of operation joined the list. All these factors have made lasers stand best when compared to the conventional techniques.

When we talk about the differentiating factors of lasers, accuracy and repeatability are unmatched. The level of processing done with lasers is best. The smooth and fine finish acquired through lasers needs no post processing. Swift operation leads to quick product turnaround time, hence increases productivity. Lasers leave very less traces in the material. The heat affected zone (HAZ) is very less on the component when processed with lasers.

Most importantly, the operating cost of the laser systems is economical.

Q What are some of the latest technological advancements and trends in this field?

Advancements in the field of Lasers are focused on aspects of quality and versatility of applications. And of course, high speed operation is one of the most important aspects that have been under continuous improvement.

With increasing global trend in Nano technology, SLTL has come with state of the art solutions that cater to micro machining applications right from aerospace to surgical components.

SLTL's machines are built to be sustainable. They are energy efficient and leave very low traces of carbon footprint.

In order to capture the domestic and global markets, we offer industry and application focused products. Since being one of the key industry players, we stick on to deliver state-of-the-art products serving to international industry needs.

Our products are manufactured to the global standards. We adhere to fine-tuned manufacturing practices with a motto to achieve Zero defect and Zero effect.

We try to represent India's technological advancements to the globe through our products. 



HEIDENHAIN

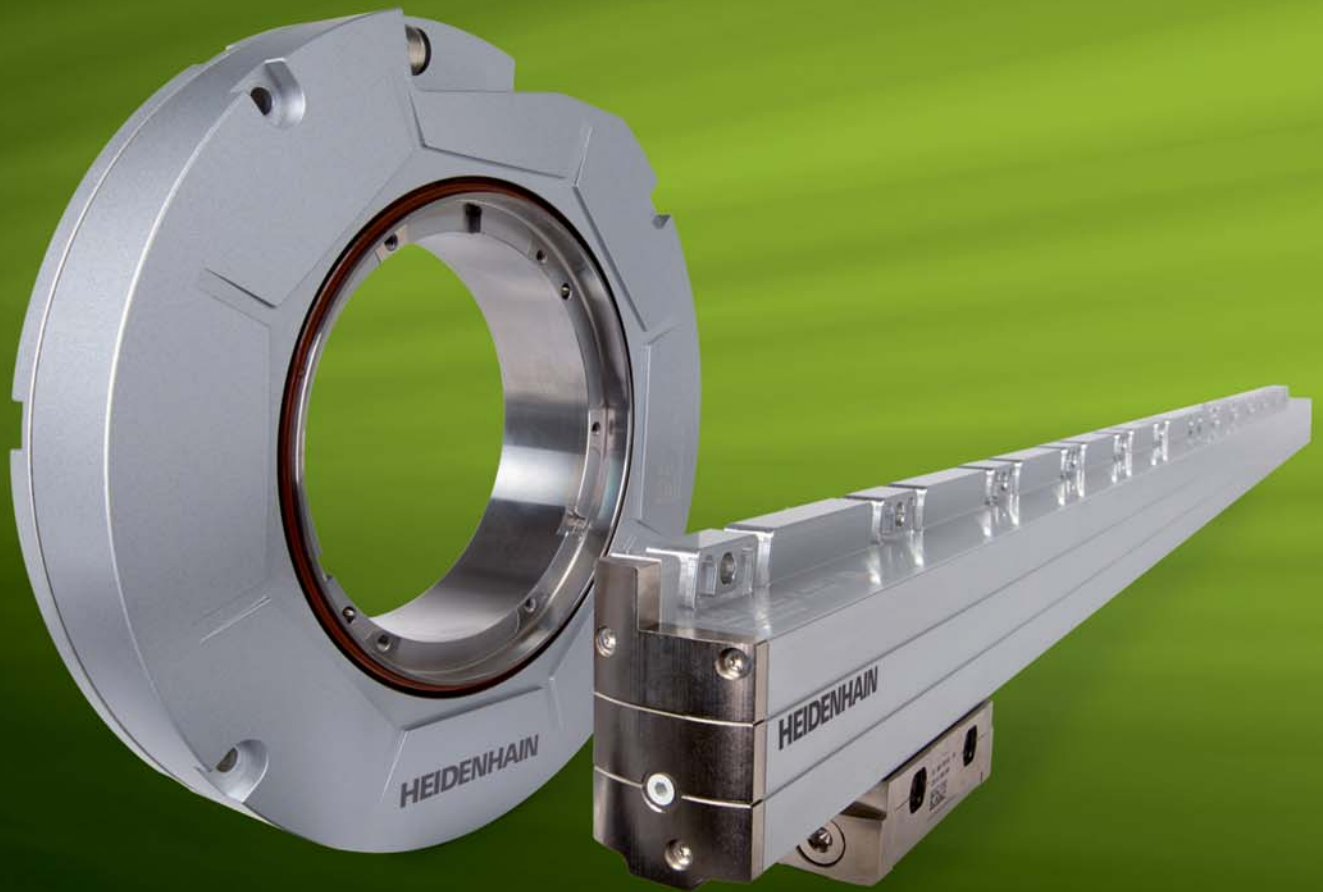

Accuracy in Continuing Development

For years, absolute linear and angle encoders from HEIDENHAIN have been setting standards for accuracy in machine tools. This will also apply to the latest generation of our encoders. Today these products are diagnosable, feature more interface variants, and are provided with functional safety including mechanical fault exclusion. This is how we continuously develop our proven products to be optimally prepared for the demands of modern machine manufacture.

HEIDENHAIN OPTICS & ELECTRONICS INDIA PRIVATE LIMITED Chennai 600031, India phone +91 44 3023 4000 www.heidenhain.in

Angle Encoders + Linear Encoders + Contouring Controls + Position Displays + Length Gauges + Rotary Encoders



Six Haas machines at IMTOS 2015

Haas Factory Outlet CNCSSIPL will exhibit at IMTOS 2015 where its team of experts will be present to discuss visitor applications and outline the benefits of using the technology

It is now confirmed that the India Machine Tools Show (IMTOS) 2015 will be attended by Haas Factory Outlet - A division of CNC Servicing and Solutions. Taking place from July 4-7, at the Pragati Maidan venue in New Delhi, visitors will be able to enjoy a good selection of popular models from the US-based machine tool manufacturer.

Machine tools form the backbone of many if not most of the major sectors of industrial activity in India, which is on the threshold of becoming a global manufacturing and economic force. With this in mind, the country must have access to strong, well-developed, reliable and precise machine tools.

Those planning to visit IMTOS 2015, of which HFO CNCSSIPL is a platinum sponsor, will be pleased to learn that no less than six Haas CNC models will be on display: an ST-10Y lathe with Y-axis; a VF-2SS Super-Speed vertical machining centre; a DT-1 drill/tap centre with HRT160SS Super-Speed servo rotary table; a VF-3YT/40 vertical machining centre with 40-taper spindle; a VF-6/50 large vertical machining centre with 50-taper spindle; and an ST-35 lathe.

Haas ST-10Y CNC lathe with Y-axis

The Haas ST-10Y is a latest generation, high productivity machine from the Haas ST range of completely redesigned CNC turning centres. Ideal for all types of round-part turning, the machine is equipped with C-axis and live tooling so that customers can turn and mill complex parts in a single set-up. The machine also features a 12-station turret that indexes tools in 0.5 seconds, helping to further reduce cycle times. The maximum cutting capacity is 228 x 355 mm, while the Y-axis boasts 101 mm of travel (± 50.8 mm from the centerline) for off-centre milling, drilling and tapping.

VF-2SS Super-Speed vertical machining centre

For visitors seeking prismatic machining solutions, the impressive VF-2SS offers 762 x 406 x 508 mm in the X, Y and Z axes, along with a 40 taper, 22.4 kW vector drive and a 12,000 rpm, inline direct-drive spindle. Rapid traverse rates are 35.6 m/min in all three axes. The machine also features a high-speed 24+1 side-mount tool changer, 1 MB program



Machine tools form the backbone of many if not most of the major sectors of industrial activity in India, which is on the threshold of becoming a global manufacturing and economic force.

memory, 15" color LCD monitor, USB port, memory lock keyswitch, rigid tapping and 208 litre flood coolant system.

DT-1 drill/tap centre with 4th axis rotary table

Any complex component machining demands can met in a cost effective manner using the Haas DT-1 drill/tap centre fitted with a 4th axis in the form of a HRT160SS Super-Speed servo rotary table. The DT-1 is a compact, high speed drill and tap machine featuring a generous 508 x 406 x 394 mm work cube yet maintaining a very small footprint. The spindle spins to 15,000 rpm, while high speed 61 m/min rapids combine with high acceleration rates to shorten cycle times. Adding the Haas HRT160SS delivers a Super-Speed servo rotary table with 570 deg/sec indexing capability.

A team of experts from HFO CNCSSIPL will be on hand at IMTOS 2015 to discuss visitor applications and outline the benefits of using Haas machine tool technology. 

A snappy solution. E2/000

Mounted in no time.

Open on the left and right.

Adapted in no time.

Can be opened on the inside or outside as open chain, "half pipe" or completely closed.

Ready to go.

E-Chains® of the E2/000 series from igus®.
Hundreds of variants ex stock.



igus®.in/E2micro

plastics for longer life®



igus® (India) Pvt. Ltd.
36/1, Sy. No. 17/3

Euro School Road, Dodda Nekkundi Industrial Area - 2nd Stage
Mahadevapura, Bangalore -560048, Karnataka, India

Phone +91-80-45 12 78-00
Fax +91-80-45 12 78-02



Maruti Suzuki introduces the diesel variant of Celerio, with DDiS 125



Kenichi Ayukawa, MD & R S Kalsi, ED M&S, Maruti Suzuki India pose next to the newly launched DDiS 125 diesel engine. Courtesy: Maruti Suzuki India Limited

Maruti Suzuki India Limited has introduced the diesel variant of its popular model Celerio. Maruti Suzuki Celerio, the car that first brought the Auto Gear Shift technology to India, now becomes the first car to offer a super compact diesel engine option to Indian car buyers. This also marks the global launch of DDiS 125, the first diesel engine designed and developed by Suzuki Motor Corporation. On the launch, Kenichi Ayukawa, MD & CEO, Maruti Suzuki, said, "Celerio, powered by DDiS 125 engine, is India's most fuel efficient car. This is also the first diesel engine designed and developed by Suzuki Motor Corporation."

Maruti Suzuki and its suppliers have together invested over Rs900 crore towards development of DDiS 125 and it comes with over 97 per cent localisation. DDiS 125 is compact and light weight. The cylinder block is all aluminium. DDiS 125 comes with a compact fuel distribution system and a turbocharger suited to a 2-cylinder engine.

Eaton supplies Supercharger to Volvo T6 Drive-E Engine

Power management company Eaton is supplying its twin-vortices supercharger to Volvo T6 Drive-E engine.

Volvo's T6 Drive-E powertrain is a 2.0 liter, 4-cylinder, direct-injection engine that combines an Eaton TVS R-410 supercharger with a turbocharger. The supercharger helps the T6 Drive-E perform like a higher displacement engine producing 302 horsepower and 295 lb.-ft. of torque, while maintaining exceptional fuel economy and lower emissions. It is available in the S60 sport sedan and XC60 sport-utility vehicle, and will be available on the all-new XC90 luxury sport-utility vehicle later this year.



"We are very pleased for Volvo and are proud to be a part of their success in winning this award," said Carlo Ghirardo, vice president and general manager, Engine Air Management, Eaton. "Our TVS supercharger, in combination with a turbocharger, is the primary technology that allows the 4-cylinder T6 engine to perform like a higher-displacement engine, while offering the fuel economy and lower emissions of a smaller engine."

The engine management electronic control unit (ECU) can engage and disengage the supercharger on the engine using an integrated clutch. This feature supports improved fuel efficiency without compromising other benefits of the supercharger, including vehicle responsiveness and low-rev torque.

Continental expands Powertrain portfolio with the acquisition of Emitec

Continental has announced the 100 percent ownership of the joint venture with Emitec Emission Control Technologies. Emitec, founded in 1986 and based in Lohmar, Germany was formerly a 50/50 joint venture between Continental and GKN.

With this acquisition, Emitec has been integrated into Continental's Powertrain Division, merging with Business Unit Fuel Supply (FS) to form a new Business Unit Fuel & Exhaust Management (FEM). In addition to production sites in Lohmar and Eisenach in Germany, Faulquemont in France and Fountain Inn in South Carolina, USA, Emitec

has a plant in Pune, India. "Our global production sites provide excellent expansion opportunities for Emitec's current products. Emitec, on the other hand, is strongly represented in the commercial-vehicle and two-wheeler sector, which can help us gain access to new market segments.

"The two wheeler market in India, for example, offers tremendous opportunities for our new Business Unit," says Dr. Markus Distelhoff, Head of the new Business Unit Fuel & Exhaust Management, and former Head of Business Unit Fuel Supply.

Mahindra becomes member of Open Automotive Alliance (OAA)



Mr. Pravin Shah, President & Chief Executive (Automotive) and Mr. Srinivas Aravapalli, Vice President - Product Development during the announcement on 28th May

Mahindra & Mahindra Ltd (M&M Ltd) has become a member of the Open Automotive Alliance (OAA), a global alliance of vehicle manufacturers, with leading edge technology, committed to bringing the Android platform to cars. The announcement was made at Google I/O, Google's developer conference in San Francisco, recently. Under the aegis of this association with Google and the OAA, Mahindra is getting ready to provide its customers with the next level of connectivity through Android Auto. Android Auto extends the Android platform into the car in a way that is purpose-built for driving. It offers next generation solution in connectivity by linking smart phones and tablets with an in-vehicle infotainment system. Speaking on the announcement, Pravin Shah, President and Chief Executive (Automotive), M&M, said, "We are happy to be part of the OAA and being the first Indian OEM to be part of this prestigious global alliance, it is indeed a moment we are proud of. We have always been committed to introducing newer technological offerings in our vehicles in an endeavour to create an enriched user experience and provide better value technologies to our customers. Going forward, after successful integration, we will be offering Android Auto in our flagship models of XUV 500 and the Scorpio as well as on our future platforms."

Renault puts their faith in HELLA LED Technology for the new Espace

In the new Renault Espace, form and function come together in an elegant combination. As a result, the fifth generation of the French crossover - first introduced as an "Initiale Paris" concept car at the IAA - is not only multifunctional and spacious, but also boasts an exceptional design. The design of the rear of the vehicle continues to elegantly integrate form and function. For this design, the French automobile manufacturer relies on the long-stand-



ing experience of the lighting expert HELLA, who gave the combination rear lamp a complex shape and equipped it with innovative LED technology. The distinctive and dynamic appearance of the new Espace can be contributed to the complex design of the two-part lamp that is embedded into the rear of the vehicle and the tailgate. At the same time, a visual extension of the vehicle is achieved through the division of the lamp into two parts.

Daimler completes the biggest CAD software migration project successfully

The large-scale project, known internally as PLM2015, has been completed and the new Siemens NX CAD software has been introduced. Key criteria to switch from the CATIA V5 design software, which had been used for many years, to Siemens NX, were the improvement of efficiency and sustainability - and the wish to integrate the product data management software currently used by Daimler, which forms the IT framework for all the development and product planning processes, with the CAD system. Dr

Michael Gorriz, CIO Daimler: "I would like to thank all the people who have worked so hard to complete our biggest IT migration project in recent decades to the planned schedule. The introduction of the new design and product data software not only means that we are well prepared for the future. We have also taken the opportunity to bring our engineering processes in line with the highest standards in the automotive industry. Daimler and Siemens will continue to work together closely on the further development of NX."

GRINDING TECHNOLOGY SEMINAR

With this seminar we show that coordinated and custom-made solutions from competent partners are more economical and offer real customer advantages.

Highlights of the seminar:

- Complete solutions around the grinding application, presented by internationally renowned Swiss companies.
- High concentration of technical competence in one location, focusing on your needs.
- Very high practical relevance based on the presentation of detailed case histories.
- Ample time for individual discussions and/or consultation.

Applications ranging from single part to mass production in the following fields:

- Tool making
- Automotive
- Mechanical engineering
- Hydraulics
- Precision parts
- Mould and die making

**Limited Seats!
Register Now**

Ms. Usha Ramakrishna
UNITED GRINDING India
Phone: +91 80 30257 600
E-mail: usha@grinding.ch



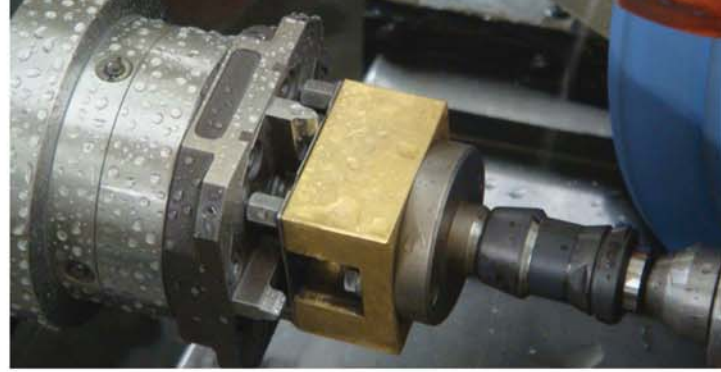

SEMINAR DATES

Monday, June 22, 2015

HYATT BANGALORE

MG ROAD
1/1 Swami Vivekananda Road, Ulsoor
560 008 Bangalore

Wednesday, June 24, 2015

HYATT REGENCY PUNE

Weikfield IT Park,
Pune Nagar Road
411 014 Pune

Friday, June 26, 2015

CROWNE PLAZA AHMEDABAD CITY CENTRE

S. G. Road near Shapath, V
380 015 Ahmedabad

Tuesday, June 30, 2015

FAIRMONT SINGAPORE

80 Bras Basah Road
189 560 Singapore

Aim

To show our common competence and experience in providing complete solutions for cylindrical grinding processes.

Profile of participants

Manufacturing / Production Engineers, Heads of grinding departments, Technical Staff in R&D, and everyone else interested in the cylindrical grinding technology.

Program

09:00	09:30	Welcome coffee
09:30	11:00	Each company presents itself
		Blaser
		Jenoptik
		EROWA
		STUDER
		3M
		Supplier of coolants
		Supplier of gauging units
		Supplier of work holding devices
		Supplier of cylindrical grinding machines
		Supplier abrasive tools
11:00	13:00	Application study with different parts
13:00	14:30	Lunch
14:30	17:00	Individual discussions / question and answer session



www.blaser.com



www.hommel-etamic.com



www.studer.com



www.erowa.com



wstinfo@mmm.com



And the 'Machie' goes to...

The finest of Indian manufacturing honoured with
The Machinist Super Shopfloor 2015 Awards



May 22,
 The Westin Pune



Traditional lamp lighting by the Chief Guest Shri Kalraj Mishra, Union Minister of MSME, Government of India



An efficient team handled the registration desk very smoothly despite the large number of people



An inspirational speech by the Chief Guest



Some of India's top industry leaders participated in the CEO Panel Discussion



Niranjan Mudholkar, Editor - The Machinist, giving his opening note

TECHNOLOGY PARTNER



INDUSTRIAL LUBRICANT PARTNER





The attendee profile can be described in three words:
Top manufacturing professionals!

THE ULTIMATE GUIDE TO PROFITABLE MANUFACTURING
MACHINIST
Super 
SHOPFLOOR 2015
Awards

POWERED BY
Ace Micromatic
Group



Winners of the People Awards along with the Chief Guest, Editor Niranjan Mudholkar and Publisher Rishi Sutrave



The Bajaj Team from Waluj took home two 'Machies'



Rishi Sutrave, Publisher - The Machinist, giving his Vote of Thanks



Even before the actual event started, the morning tea-time was utilised very well for networking by the attendees

ASSOCIATE PARTNERS



JURY MEET PARTNER



KNOWLEDGE PARTNER



MAGAZINE PARTNER





There are three key elements to this initiative: industry, government and financial institutions. The role of the industry should be to develop people, plants, processes and partnerships.”

Rajeev Kaul
Managing Director & Group CFO,
Aequs India

Innovation, skill development and cost competitiveness will be the key elements of making it happen.”

Niranjan Mudholkar
Editor - The Machinist & Moderator of the CEO Panel Discussion

The Make in India campaign encompasses skill development, job generation, growth for the country, and manufacturing not just for India but also for the world.”

GK Pillai
MD & CEO, Walchandnagar Industries Ltd.

Some of India’s finest CEOs came together to deliberate on the ‘Make in India’ initiative during the knowledge session of our awards ceremony.

While the manufacturing industry has been delivering steadily to the economy over several decades, the need of the hour was to put a clear focus on it with the aim of taking it to the next level. The ‘Make in India’ campaign has surely served the purpose of bringing the industry to the forefront. So we held an insightful and interactive discussion on this topic with six of the key industry leaders during the knowledge session leading into the Awards ceremony.

Like GK Pillai, MD & CEO, Walchandnagar Industries Ltd, said it, manufacturing is probably the only industry that has the potential to cater to the job requirements of the millions of Indian youth. So it is all the more essential that this industry gets its

due. And surely ‘Make in India’ is one of the ways of doing it.

“The way Rolls-Royce interprets Make in India is: design in India, develop in India, make in India for the region as well as for the emerging markets in the world. And soon enough we would be serving the developed markets in the world as well,” said Kishore Jayaraman, President - Rolls-Royce, India and South Asia. Incidentally, Rolls-Royce has already created a fantastic supply chain in India that is all set to leverage India’s fantastic engineering talent, knowledge base and capabilities to develop products. That is the crux of this initiative.

As Sudhir Kumar Mishra, MD & CEO, BrahMos Aerospace, rightly said it, for this campaign to succeed, we need to look beyond manufacturing. “Indian companies should not just think about man-

Indian companies should not just think about manufacturing but think about re-engineering. Come out with a better design and a better product with enhanced functionality at a cost competitive price."

Sudhir Kumar Mishra
MD & CEO, BrahMos Aerospace

It is not just about creating manufacturing locations in the country but it is about having the capability of driving technological changes, and about empowering and educating people."

Nitin Chalke
Managing Director –
India, Eaton



For me 'Make in India' is a vision, which says 'put the focus to create jobs', 'put the focus to what it takes to create the jobs' and 'put the focus to take the economy forward'."

Kishore Jayaraman
President - Rolls-Royce, India and South Asia

A key element of Make in India has to be a focus on advanced component manufacturing capabilities if we are to become a global manufacturing prowess. Otherwise, it would remain an assembly driven operation."

Krishan Sachdev
MD, Carrier Midea India Private Limited

ufacturing but think about re-engineering. Come out with a better design and a better product with enhanced functionality at a cost competitive price," he remarked.

For Nitin Chalke, Managing Director – India, Eaton, skill development and driving innovation will play critical roles in taking the Make in India initiative forward. "It is not just about creating manufacturing locations in the country but it is about having the capability of driving technological changes and about empowering and educating people," Chalke added.

Krishan Sachdev, MD, Carrier Midea India Private Limited, too agrees that Make in India is a great initiative and resonates well with the needs of the country but at the same time we need to make sure that the environment is correct and take the right steps'. He also adds that we also need to ensure that the local market is addressed well; Make in India cannot be just for the exports market. Rajeev Kaul, MD &

Group CFO, Aequus India, says that there three key elements to the campaign: Industry, government and financial institutions. "Industry needs to develop people, plant, processes and partnerships. The government needs to enhance ease of doing business, encourage entrepreneurship, nurture and protect IP developments while financial institutions need to partner with and encourage entrepreneurs."

The discussion drew excellent response from the audience. For example, Viren Joshi, President & CEO, Sigma Electric Manufacturing Corporation, spoke about the need for being cost competitive. Ravind Mithe of KPMG talked about having a strong government policy, while Santanoo Medhi, MD & CEO, Premium Transmission Ltd. emphasised on the importance of producing next generation products. Hugh Dowding – Director – Motul SA and Head for Global MotulTech Business, pointed out the significance of excellence, irrespective of the cost.

Chief Guest's Address

Innovation and Quality vital for 'Make in India'

Delivering his special address as the Chief Guest at The Machinist Super Shopfloor 2015 Awards, Shri Kalraj Mishra, Union Minister of MSME, Government of India, said that innovation and quality form the crux of Prime Minister Narendra Modi's 'Make in India' campaign.

"Equally important are the parameters of productivity and sustainability. 'Make in India' is all about Zero Defect and Zero Effect," he said. "If we are to make India a global manufacturing power then it is critical that these parameters are adhered to. I am extremely happy that these very parameters are being highlighted through this Awards platform." The Machinist Super Shopfloor 2015 Awards honoured some of the finest manufacturing plants across India in five categories: namely Innovation, Quality, Productivity, Sustainability and Safety.

The Machinist Super Shopfloor 2015 Awards has filled in the gap for a reputed, fair and industry-oriented awards platform for the manufacturing sector. The Chief Guest also underlined this fact during his address. He further added: "I must congratulate the organisers for creating this forum which will excite and inspire the manufacturing sector to further raise its bars in terms of progress, performance and productivity."

The honourable Minister highlighted the manufacturing industry's immense contribution in the country's economic and social development and said that the Government is committed to the progress of the sector. Drawing attention to the fact the skill development is critical to the growth of the industry, he informed the audience that his Ministry has created industrial profile of every district in the country and skill mapping has been done with the aim of identifying and, subsequently, filling up the gaps.

"If we are to make India a global manufacturing power then it is critical that the parameters of Innovation, Quality, Productivity, Sustainability and Safety are adhered to at the highest level. I am extremely happy that these very parameters are being highlighted through The Machinist Super Shopfloor Awards platform."



Left: S Sreekanteswar, GM, Market Development & Strategy, Micromatic Machine Tools Pvt Ltd, delivering the Welcome Address
Right: Mr Sreekanteswar felicitated by Editor Niranjn Mudholkar



Left: Nitin Kanse, Regional Head – West & East, (Toughbook), Panasonic India Pvt. Ltd. felicitated by Mahadev B, GM- B2B, WWM
Right: Mr Kanse giving a presentation on the usefulness of the Toughbook on the Shopfloor



Left: Yatendra Kumar, Business Head – MotulTech India, sharing some interesting and insightful case studies with the audience
Right: Mr Kumar felicitated by Ranjan Halder, Ad/Sales Head – B2B, WWM



Winner in SMEs: **Demag Cranes & Components (I) Pvt. Ltd. (Terex - Material Handling) Chakan**



Runner up in SMEs: **Sterling Generators Pvt. Ltd. , Silvassa**

(Also on the stage along with the Chief Guest is Sudha Sarin, VP-Marketing, Power2SME)



Winner in Large Enterprises: **Bajaj Auto Ltd. , Commercial Vehicle Division - Waluj, Aurangabad**



Runner up in Large Enterprises: **Eaton India Hydraulics, Pune**

(Also on the stage along with the Chief Guest are Nishant Saini - Head - Product Marketing (Manufacturing Stream) Technology Group & Sambit Pradhan -Director Business Development, APAC (Technology Group), from Geometric Ltd.)





Winner in SMEs: **Toshiba Transmission and Distribution Systems (India) Pvt. Ltd., Hyderabad**



Runner up in SMEs: **Cummins Turbo Technologies India Pvt. Ltd., Dewas**

(Also on the stage along with the Chief Guest are Jiten Goswami – Chairman – Atlantic Lube /Motul India and Hugh Dowding, Director – Motul SA and Head for Global MotulTech Business)



Winner in Large Enterprises: **Escorts Limited, Faridabad**



Runner up in Large Enterprises: **Bajaj Auto Ltd., Commercial Vehicle Division - Waluj, Aurangabad**

(Also on the stage along with the Chief Guest are Jiten Goswami – Chairman – Atlantic Lube /Motul India and Hugh Dowding, Director – Motul SA and Head for Global MotulTech Business)





Winner in SMEs: **Mahle Behr India Pvt. Ltd. , Chakan**



Runner up in SMEs: **Sigma Electric Manufacturing Corporation Pvt. Ltd., Pune**

(Also on the stage along with the Chief Guest are Chandra Nataraja, MD, Knorr Bremse, & Subrahmanya Kumar, Country Head – India, Tyrolit)



Winner in Large Enterprises: **Volkswagen India Pvt. Ltd., Chakan, Pune**



Runner up in Large Enterprises: **AMW Motors Limited, Bhuj**

(Also on the stage along with the Chief Guest are Shrikant S. Bairagi, MD – India, Tremec Torque Transfer Solutions, & Madhu Ranjan, MD, ElringKlinger Automotive Components India)





Winner in SMEs: **RSB Transmissions (I) Ltd., Pune**



Runner up in SMEs: **Cummins Technologies India Pvt. Ltd., Pithampur**

(Also on the stage along with the Chief Guest is Dr. Dhananjay Kumar, Managing Director (Electric Vehicle Program), Thor Power Inc.)





Winner in Large Enterprises: **Ashok Leyland Limited, Pantnagar**



Runner up in Large Enterprises: **Hyundai Motor India Limited, Engine – 2, Chennai**

(Also on the stage along with the Chief Guest are Ravind Mithe, Senior Partner in Strategy & Operations, KPMG India, & Rajeev Mittal, Head IT/IS, Piaggio Vehicles Pvt. Ltd.)





Winner in SMEs: **Jaycee Autofab Pvt. Ltd., Faridabad**



Runner up in SMEs: **Si2 Microsystems Pvt. Ltd., Bangalore**

(Also on the stage along with the Chief Guest is Nitin Kanse, Regional Head – West & East, (Toughbook), Panasonic India Pvt. Ltd.)





Winner in Large Enterprises: **BrahMos Aerospace, Kanchanbagh, Hyderabad**



Runner up in Large Enterprises: **LG Electronics India Pvt. Ltd., Greater Noida**

(Also on the stage along with the Chief Guest is Nitin Kanse, Regional Head – West & East, (Toughbook), Panasonic India Pvt. Ltd.)





Overall Winner in SMEs: **Tata Lockheed Martin Aerostructures Ltd., Hyderabad**



Overall Runner up in SMEs: **Cooper Corporation Pvt. Ltd., J1/J2 – additional MIDC, Satara**

(Also on the stage along with the Chief Guest is S Sreekanteswar, General Manager, Market Development & Strategy, Micromatic Machine Tools Pvt Ltd.)



Overall Winner in Large Enterprises: **Mahindra & Mahindra Ltd., Igatpuri**



Overall Runner up in Large Enterprises: **Kirloskar Brothers Limited, Sanand, Ahmedabad**

(Also on the stage along with the Chief Guest is S Sreekanteswar, General Manager, Market Development & Strategy, Micromatic Machine Tools Pvt Ltd.)





The Machinist Super Next Generation Leader 2015:
Amit B. Kalyani, Executive Director, Bharat Forge Ltd



The Machinist Super Entrepreneur 2015:
RK Behera, Founder and Chairman, RSB Group



The Machinist Lifetime Achievement Award 2015:

Farrokh N. Cooper, Chairman and Managing Director, Cooper Corporation Pvt. Ltd



The Machinist Super CEO 2015:

Sudhir Kumar Mishra, MD & CEO, BrahMos Aerospace





AWARDS



"The Machinist Super Shopfloor 2015 Awards ceremony was very well organised. The Award recognises the manufacturers who are excelling on the shop floor management practices, which is crucial for the success of "Make in India" initiative. Awarding exemplary work is a great motivator

for an individual or the Team to excel and to innovate, and thereby drive a manufacturer to achieve market leadership. The inter-active Panel Discussion was also very well organised. I am sure that all attendees must have got lot of inputs for achieving the excellence in various aspects of manufacturing. I wish The Machinist Team a bright future in their journey ahead!"

HIRAMAN AHER, VP – MFG. OPERATIONS (NASHIK & IGATPURI), MAHINDRA & MAHINDRA LTD

"The overall event was Superb; hats off to the team. Well organised from Start-to-End. "Right from the invitation - the participation process was crisp and clear. All the queries were handled in most courteous manner and resolved on real time basis. There were no hassles for sending large files, since the issues were proactively considered and measures were taken to avoid problems. All the schedules and updates were posted on website on real time basis. Invitations were sent well in advance, which helped us to plan and organise. Location and venue of the event was good. We expect more such events and sharing of case studies, which will motivate other organisations to adopt good practises, and foster the healthy Co-optive (Competitive and Co-operative) atmosphere within industry and its leadership. 'The Machinist' team has lighted the torch of "Make in India" Marathon - we will take it forward."

SHRIRAM PATIL, SR.MANAGER, BUSINESS EXCELLENCE, AMW MOTORS LTD.

"Excellent event overall. The CEO Panel discussion's highlight was excellent anchoring and to the point discussion. The chief guest's speech was repetitive at some point but nevertheless was very powerful. And the awards presentation ceremony itself was very vibrant.

ANIL SINGH, DIRECTOR - OPERATIONS & MATERIALS, AMW MOTORS LTD.

"This was wonderful experience to me and sessions were informative and useful. Liked the way the stage was set; it represented the shopfloor theme very well. Time giving for question-answer session was really appreciable during CEO Panel Discussion, which was very well moderated by Niranjan.

RAJEEV MITTAL, HEAD IT/IS, PIAGGIO VEHICLES PVT. LTD.

"Learnt about many new things through the CEO panel discussion. And the awards presentation ceremony gave us thrill like the Filmfare function.

M.N.S. PRASAD, DY. MANAGER, TOSHIBA TRANSMISSION AND DISTRIBUTION SYSTEMS INDIA PVT LIMITED, HYDERABAD

This was truly wonderful experience in terms of learnings and interacting with industry's best leaders. Thanks to whole team for the excellent arrangements and driving collective wisdom of industry for Make in India to happen successfully.

SUNIL KUMAR TIWARI, GM, ENGINE, GEAR BOX, CWP & AXLE, ASHOK LEYLAND



This is what some of the attendees had to say about the inaugural edition of 'The Machinist Super Shopfloor Awards'



This is very good initiative which recognizes the efforts and achievements of manufacturing teams working on the shopfloor. It was nice to hear from eminent personalities from various industry sectors on "Make in India" and wonderful to listen to the honorable Chief Guest Shri. Kalraj Mishra. We are humbled to receive the unique award trophies and are very much thankful to Mr. Niranjan and his entire team for creating such an opportunity for us. We will definitely look forward for next event and give us our best wishes for make it more successful.

ANIL SHELKE, MGR (TPM 3WH), COMMERCIAL VEH DIV., BAJAJ AUTO LTD., WALUJ, AURANGABAD.





The function was organised in a very professional and yet in a personal and homely manner which made everybody feel comfortable throughout the day. We have to congratulate you for the enormous efforts you took in that regard. Your function has motivated Indian Industry to move forward on the Make in India initiative of the Government.

FARROKH N. COOPER, CHAIRMAN & MANAGING DIRECTOR, COOPER CORPORATION.

It is a great start to recognise and appreciate the different activities in manufacturing sector. The award categories touched each aspect of the industrial activities. 'The Machinist' will certainly play a catalytic role to unite the manufacturing eco system. 'The Machinist' has a bigger responsibility to make the dream of 'Make in India' come true. My best wishes to the team in their endeavours.

NITIN GHODGAONKAR, DIRECTOR OPERATIONS, SI2 MICROSYSTEMS



The CEO Panel Discussion was probably the most interesting part of the event. Lots of good thoughts and comments from the Industry Leaders. Niranjana conducted it in a very professional and conducive manner.

SUBHASIS CHATTERJEE, MD, EATON FLUID POWER LIMITED, (HYDRAULICS GROUP)

"It was very well organised and conducted event! Great job by Niranjana & team.

SHRIKANT S. BAIRAGI, MD – INDIA, TREMEC TORQUE TRANSFER SOLUTIONS DERABAD



The stage was very well designed; perfect for the occasion. It shows the commitment and devotion of the Machinist Team. It overwhelms me to place it in my memory, getting connected on LinkedIn has 'connected me eternally' today giving utmost satisfaction and glory only because of your efforts

down the line. I can see the combination of hard and smart work to avail the precious time of our Hon'ble Union Minister (MSME) for awards presentation ceremony and motivation for everybody.

Our Hon'ble Union Minister's presence on the stage assured his ownership by the time given and humility shown towards each of the participant. It shows our Government's commitment towards the industry.

SANJAY AGARWAL, PLANT HEAD JAYCEE AUTOFAB PVT. LTD.

"It was a wonderful event."

PRASAD AKOLKAR, ASSISTANT GENERAL MANAGER – QA & HSE, TEREX MATERIAL HANDLING AND PORT SOLUTIONS

**Are you using plastics innovatively
in the automotive industry?**

Then watch out for

P  **lymers**
The Economic Times
Awards 2015

For Nomination Details: **Niranjana Mudholkar**
niranjana.mudholkar@wmm.co.in | +91 22 22735681

For Partnership Details: **Rishi Sutrave**
rishi.sutrave@wmm.co.in | +91 22 22735756



BluePlus – Fritz Studer AG helps your customers use resources efficiently

In future, energy efficiency will also be an important issue in machine construction. STUDER, as well as all the other companies in the UNITED GRINDING Group, has qualified for the «Bluecompetence» label. You can find out here what this label stands for and how STUDER tackles the subject of energy efficiency.

Global energy requirements are constantly increasing. In order to counteract the rapid increase in energy and climate change, the available energy must be used more efficiently and effectively. Energy efficiency is also becoming an important topic in machine tools. The Verband Deutscher Maschinen und Anlagenbau e.V. (VDMA - German Engineering Federation) has therefore taken up this topic with the «Bluecompetence» label. Sustainability is the focus and the label aims towards establishing energy efficient products, technologies and processes that save on resources. This label may only be

AG is a major player in state-funded projects concerned with energy efficiency, also in collaboration with universities. In these projects improvements to grinding machines have been developed, which once implemented will lead to a reduction in the energy consumed by machines.

These improvements have been achieved by taking constructive measures in the area of cool-ant supply and the extraction system and by using energy-optimised electric components. The software used in STUDER machines contributes in a major way. Fritz Studer AG has won the PRODEX Award for Innovation 2012 (in Basel) and the Intec Prize 2013 (in Leipzig) for the «StuderTechnology» software. This software reduces and optimises processing times (by up to 50 percent) and the energy consumption of STUDER grinding machines. This helps considerably to save energy. This is also what the respective juries thought when they awarded the prizes. Below



you can see four examples of where STUDER is taking action to design its cylindrical grinding machines more energy-efficiently.

Granitan® machine bed: The manufacture of STUDER machine beds made of Granitan® requires less than 40 percent of the energy needed for a comparable iron cast bed.

StuderTechnology: «StuderTechnology» immediately optimises finishing processes even more and reduces processing times down by 50 percent.

StuderGRIND / StuderWIN: Thanks to a detailed process simulation for setup of a machine for new production tasks, downtimes and spoilage can be avoided. Energy and raw material requirements are also reduced.

Machine components: More energy efficient equipment in the coolant and extraction system. Further physical saving-project measures are being developed all the time.

used by companies that have acknowledged the conditions of use in writing and have committed themselves to the implementation of energy and resource efficient solutions. Having been given the rights to use this label, UNITED GRINDING Group and therefore STUDER too are pioneers in the industry. Optimised use of resources begins with consideration and Analysis of the machining process chain. The best energy is always the energy which is not used, or can be avoided. It is therefore important that the best finishing strategy and the most efficient production technology is ascertained for each workpiece.

Not every measure is the best solution for every machine to achieve the maximum resource efficiency. It's more about ensuring that the right thing is done at the right moment. The goal must be to improve production times, shorten processing times and save on energy costs. This can not only save energy but also provide customers with a direct benefit. Fritz Studer

AG is a major player in state-funded projects concerned with energy efficiency, also in collaboration with universities. In these projects improvements to grinding machines have been developed, which once implemented will lead to a reduction in the energy consumed by machines.

The STUDER concept of the «4BlueSteps» is used to implement these principles.

Step1: The optimal selection of components and dimensioning of the measure.

Step2: Standby Management optimised to customer requirements.

Step3: The software «StuderTechnology».

Step4: EE4C – a concept, which, in collaboration with the Swiss Federal Institute of

Technology in Zurich/Inspire, has been developed to enable the optimal design of a machine's configuration with regard to the energy consumed for each produced workpiece.

For more information, visit: <http://www.grinding.com/en>



Designed for corners: Curved linear guides from igus

New lubrication-free drylin solutions for custom design concepts

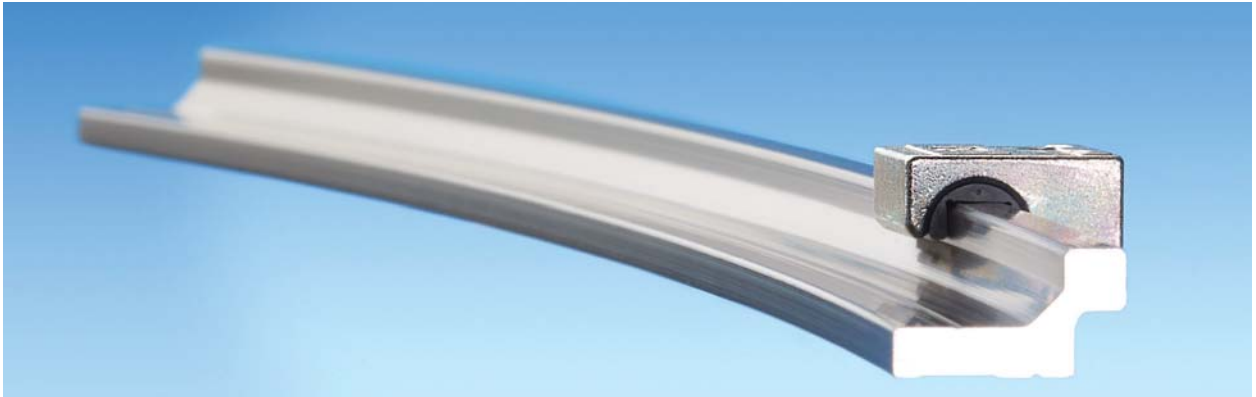

The curved guide rails are made of aluminium and have an exceptionally resistant hard-anodised coating. In the maintenance-free application, cornering becomes trouble-free without tilting or seizing. (Source: igus GmbH).

Individual requirements and space optimisation calls for new ideas in the field of design. In the instance of linear plain bearings, the straight structured rail guide has caused certain limitations. Now the plastics expert igus also offers curved drylin rails, which give the designers more freedom such as, in the cabins of construction and agricultural equipment.

Utilising the already proven and tested drylin W linear plain bearings, igus has developed a new offer for linear guides that provide a functional reliable and cost-effective solution even for curved travel paths. The curved guide rails are made of aluminium and have an exceptionally resistant hard-anodised coating. Customised guide carriages thereby implement cornering without tilting or seizing. In addition, appropriate hand clamps can be added. Low installation effort and maintenance-free operation are the strengths of the new system, which like all drylin systems combine low friction coefficients with dirt-repellent dry operation. The drylin aluminium rails are also easy to machine individually and are characterised by their light weight.

Use in driver's cabs

The driver's cab of an agricultural machine is a good example of how curved guide rails can increase flexibility in the adjustment of monitors, seats or fittings and ideally adapt to the general design of the machine. Every agricultural machine

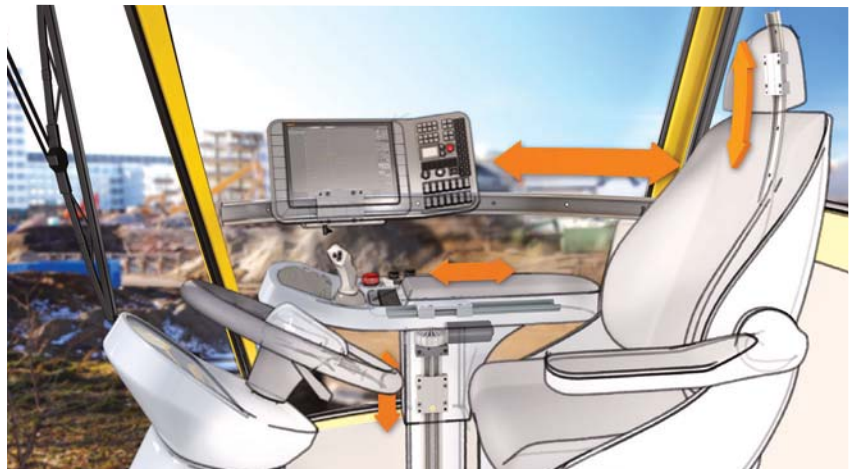

Examples for the versatile use of curved section rails in the driver's cab of an agricultural machine: lubrication-free mobility in all directions, even in the most confined of spaces. (Source: igus GmbH).

igus manufactures the section rail according to these specifications and provides the individual rails and linear bearings from the range of drylin W and drylin T.

has its specific frame sizes and design requirements. Adaptable, modular components create the necessary leeway to achieve custom solutions. The curved drylin rail can be configured. Within certain physical limits, users can choose their own bending radius and therefore optimally fit in the driver's cab. igus manufactures the section

rail according to these specifications and provides the individual rails and linear bearings from the range of drylin W and drylin T.

For more details, contact:

Vinayak Shetty, Product Manager, igus (India) Private Limited;

Cell: +91-9341136381;

Email: vinayak@igus.in; Website: www.igus.in



Program expansion – NEW Chip geometry – NEW Grades

CERATIZIT presents a new and complete program for copying and face milling applications with MaxiMill 251-RS. New geometries in combination with the new milling grades SILVERSTAR™ and BLACKSTAR™ represents the new and complete button milling insert program of CERATIZIT.

What's New:

- Complete and consistent geometry program for a wide field of applications
- Designation of the indexable insert geometry referring to the CERATIZIT designation system
- Numbered cutting edge for optimum run out properties of the tool (from Ø10mm)
- 8-times indexing for maximum economy at varying conditions
- Detailed selection opportunities for wide range of applications
- Milling grades: SILVERSTAR™, BLACKSTAR™.

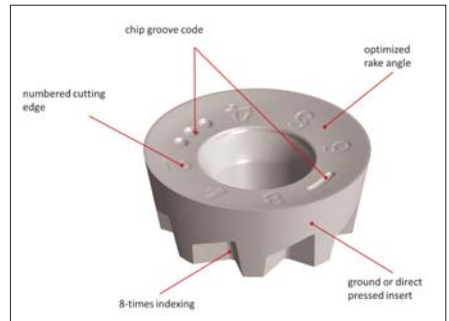

For more information: www.ceratizit.com/

“All in One” function NC Spot Drill

The “All in One” function NC Spot Drill from Nine9, Taiwan with a patented indexable carbide insert contributes high efficiency by performing various multiple application as:-



- Grooving
- Helical grooving milling.
- Engraving
- Spot drilling
- Chamfer turning
- Face grooving milling
- Internal turning
- Internal chamfering

- Facing grooving
This “Multifunctional Cutting Tool”, used in CNC Lathe and CNC Machining Centers, contributes to increased cutting speed, long tool life, best position accuracy and reduction in cycle time.

NC Spot drill shank diameter ranges from ø5 to ø20mm and inserts are having four cutting edges and available in 45°/60°/82°/90°/120°/142° angles for different applications.

The latest coated carbide grade helps you to obtain higher speed and feed rate therefore reducing the cycle time.

For more details, contact *Stitch Overseas Private Limited*,
Tel.: + 91-124-4755400; Fax: + 91-124-4755430;
Helpline No: +91-9313361202 E-mail.: stitch@vsnl.com;
Website: www.stitchtools.com

“All in One” function NC Spot Drill

ATM 160 - Machines with automated job feeding feature:

Vertical Line Series of machines with automated job feeding feature and special high speed electro spindles are quite suitable for mass production jobs. With modular tooling concept these machines are capable of performing variety of operations. The concept of moving the inverted vertical spindle head in all the axis and keeping the front space of base open for customisation of tooling requirement makes this machine series unique. The multi function station on front side of machine ensures max flexibility for customized tooling like rotary milling head, grinding heads, long boring tools, etc.

TMC 750-1250 - Produce complete component in single set-up:

Turn-Mill Centre gives flexibility to produce complete component in single set-up and distinct competitive edge.

TMC 750-1250 is the most robust machine designed for heavy and uninterrupted cutting to achieve superior finishing and long term accuracies. Based on the proven Step-up Structure Concept with all the tried and tested features, TMC Series of Machines provides an ideal partner for machining large diameter components. The machine is equipped with 12-Station High Torque Servo Motor. The Tool Turret can perform various applications like PCD Drilling and Tapping, OD & ID profiles with Radial and Axial Live Tools. Machine is with robust bed and single piece 30° slant saddle which is made out of high grade cast iron for rigidity, heavier cut & fast production with virtually no vibration even on hard part machining.

Contact - *Jyoti CNC*; Phone: +91-2827 - 287081/082;
Emails: info@jyoti.co.in / sales@jyoti.co.in; Website: www.jyoti.co.in



Renishaw's EVO Project – additive manufacturing for industrial use

Renishaw is pleased to unveil the machine that it is developing specifically for production manufacturing. Provisionally named EVO Project, it is the first additive manufacturing system designed and engineered in-house at Renishaw and reflects the company's 40 years of experience in supplying high quality equipment to demanding global manufacturing businesses.

The new machine, which has a strong emphasis on automation, monitoring technologies and reduced operator interaction, is designed for single material industrial production. Powder handling is almost entirely hands off, whilst powder recirculation, recycling and recovery are all carried out within the inert atmosphere of the system, protecting both the user and the integrity of the material.

The EVO Project machine incorporates a high power 500 W laser which will aid productivity whilst still maintaining precision and surface finish. It also boasts a class leading



high capacity filtration system, a large 19" HMI user interface and intelligent workflow to further reduce the need for operator interaction.

The new machine, which is planned to be available in the second-half of 2015, is designed to complement and not replace the current Renishaw AM250 system which is better suited for flexible manufacturing and research applications where changes between materials are a requirement. The AM250 has an interchangeable hopper system which allows various materials to be used on the same machine.

Renishaw continues to develop the AM250 system which is also benefitting from some of the developments

made for the EVO Project machine. This has led to the recent introduction of the PlusPac™ upgrade pack which offers improvements to Z-axis seals and chamber lighting, plus substantially improved gas recirculation and filtration.

For further information on the EVO Project please visit www.renishaw.com/evoproject

Fresmak ARNOLD SC vice

ARNOLD SC High Precision Vices are compact and self-centering, they also maintain constant length as well, which makes them specially valid for working in 5 – axis machining centers.

They are specially designed to work on machining centers with small tables, as well as, in 5-axis controlled centers. Their compact design with exterior guides avoids deformation and the clamping force is distributed throughout the width.

They have a threaded right-left spindle, which can be operated with standard key. Moreover, the interchangeable jaws can reach a height of 125 mm, this means they can overcome the biggest obstacle for this type of work, that is, avoiding collisions with the machine turrets or the rotation of the table.

The ARNOLD SC vices have also Special Uses which go beyond the general uses. Although the clamp is specially designed to work in 5-axis machining centers, it is also useful for other types of machining. The picture shows four 125 size clamps placed on a pallet of 630x 630 inside a horizontal ma-



chining center used for machining of high quality results .

The self-centering vice allows us to manufacture countless pieces such as prismatic or cylindrical parts. Furthermore, the repeatability of the self-centering reaches 0.01 mm and the accuracy thereof reaches 0.02/0.03mm. It has also clamping force up to 40 kN with a torque of 120 Nm. These are also guaranteed when holding workpieces inside out.

In addition, should the position of their mouths be changed the clamping field will reach up to 264 mm clamping. Another great advantage is that it can be equipped with our full range of special jaws as well as special jaws designed by the user, keeping in all cases the self centering accuracy.

*For more customized solutions please contact at:
Fresmak ARNOLD Precision Engineering Pvt. Ltd;
Tel No +91 (80) 6765 4250;
Email info.india@fresmak.com; Website: www.fresmak.com*



LVD expands its series of electric press brakes

LVD Company nv has expanded its Dyna-Press Series of compact, portable, high-speed electric press brakes with two 24 ton models that offer higher capacity and a longer working length.

Engineered for cost efficient bending: The Dyna-Press series are ideal for cost efficient bending of small parts. Rapid acceleration and deceleration of the electrical servo-driven ram delivers bending speeds up to 25 mm/s. The new models can handle bend lengths up to 1250 mm and have 24 tons of bending force. The coupling of the ram and servomotors is realized through two heavy duty ball screws to distribute force and tonnage evenly across the working length.

Compact design: Compact and portable with a footprint of just 1140 x 1760 mm, the new Dyna-Press models save on valuable floor space and can still be conveniently relocated using a standard forklift.

Two models 24/12: Dyna-Press 24/12 standard models are equipped with two CNC controlled axes (X, R) and additional Z1 and Z2-axes for the Dyna-Press 24/12 Plus model. An extensive range of upper and lower tools are available for and can be used on the Dyna-Press.

The Dyna-Press 24/12 standard model has a 12" touch screen which allows operators to easily adjust individual pa-



rameters. The 24/12 Plus model offers TOUCH-B Lite control which enables the operator to create and simulate 2D-designs on a 15" touch screen. Additionally the TOUCH-B controller is compatible with LVD's offline bending CAM software CADMAN-B®.

For more information, contact:

*Tel. +32 (56) 43 05 11, Fax +32 (56) 43 25 00,
e-mail: marketing@lvd.be or www.lvdgroup.com*

Doosan Infracore Machine Tools win the Red Dot Design Award



The FM 200/5AX Series wins Doosan Infracore Machine Tools the Winner Award at the Red Dot Design Awards for the second year running. On March 29, 2015, Doosan Infracore announced that it had received the winner award in the category of product design at the Red Dot Design Awards 2015 for its FM 200/5AX, a high-speed, high-precision machine tool series. The company has now won the Winner Award in Product Design at the Red Dot Design Award for a second consecutive year following its receipt of the award

in 2014 for its PUMA SMX series. The Red Dot Design Award is widely regarded as one of the top three design recognitions in the world along with the iF Design Awards and the IDEA Design Awards. For each award in three main categories – product, communication, and concept – candidate products/ideas are subjected to a comprehensive evaluation in terms of design, creativity, practicality and eco-friendliness.

The FM 200/5AX is the highest-speed 5-axis machining center on the market. Based on the concept of 'hexagonal edges,' the external design of the series is characterized by visual stability while symbolizing the robust performance of the machine tool. The design excellence of the machine tool series had already been recognized in Korea with its receipt of the Good Design Award 2014.

"The concept that is currently gaining considerable traction in the field of machine tool design is 'sensitivity combined with robustness,' which means that ergonomic designs are becoming increasingly important in the industry," said an official of Doosan Infracore. "The company's second consecutive Red Dot Winner Award attests to the fact that Doosan Infracore has succeeded in markedly boosting both the user-friendliness and the emotional quality of its machine tools."



Haas cooling options offer greater productivity

The Haas Flood Coolant Ring, which is standard on all VM and VF series Haas machine tools, provides a cascade of coolant that thoroughly lubricates the cutting area, while dispersing chips produced during cutting.

The coolant ring concept is a significant improvement over traditional hose-based systems. The ring's fully adjustable nozzle tips direct precision coolant flow to the tool from many angles. The nozzles are easy to move, and the ring is positioned for maximum clearance and ease-of-use. While the Flood Coolant Ring serves as the main Haas coolant delivery system, numerous other cooling options are available. For instance, the Haas Programmable Coolant Nozzle, or P-Cool, can take up numerous positions to serve any tool selected, long or short. Another effective method of getting coolant to the cutting zone is to deliver a high pressure blast through the tool tip. Here, the Haas Through-Spindle Coolant (TSC) system, which is particularly effective when drilling deep holes or milling deep pockets, is available in either 300 or 1000 psi (20 or 70 bar) configurations.

For machine shops using modern carbide tools with advanced coatings to cut materials in a dry environment, there is significant potential to recut chips not evacuated from the cutting area (a primary contributor to early onset tool wear). To overcome the issue, Haas offers an optional Through-Tool Air Blast system (as an add-on to the TSC system) that removes chips from the machining zone before they can be cut a sec-



ond time. This is particularly useful for deep cavity machining.

Serving a similar function is the Haas Auto Air Gun. This system is ideal when using small tools that are not suitable for through-tool air delivery. The Haas Auto Air Gun is also a great complement to the Through-Tool Air Blast system in demanding dry machining applications that require a higher volume of air delivery. For applications where coolant cannot be deployed, but the tool still needs to be kept lubricated, the new Haas Minimum Quantity Lube option provides the solution.

For further information please contact:

<http://www.cnssipl.com/> or www.HaasCNC.com

Collet chuck module for cylindrical parts

SCHUNK, the competence leader for clamping technology and gripping systems extends its modular system for efficient workpiece clamping with a particularly smart collet chuck module for parts with cylindrical shanks. Lengths of pipes, shafts, and other small parts can be precisely clamped with the SCHUNK VERO-S SEZ within a very short time, and can be machined from five sides with an optimal accessibility. The same applies for unstable workpieces with a short shank. Since the system can be quickly made ready for use, it is particularly suitable for machining individual pieces, small series such as plungers and ejectors in tool and mold making. First of all, the comparably light but robust collet chuck module is put onto an existing SCHUNK VERO-S quick-change module, is equipped with a workpiece, and then the pull-down jaw system is activated. This ensures a maximum clamping precision, great dimensional stability, and an adjustable depth stop provides for a

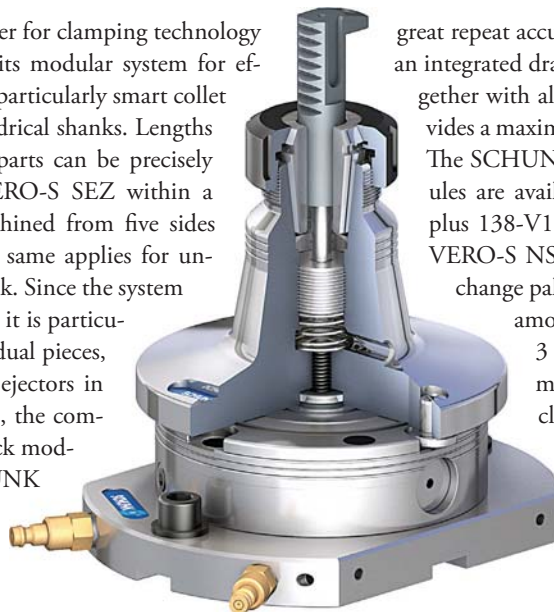

The SCHUNK VERO-S SEZ collet chuck module was particularly designed for machining small components with a cylindrical shaft. It offers a high degree of flexibility.

great repeat accuracy. Coolant is discharged through an integrated drain. Since the system can be used together with all common ER collet chucks, it provides a maximum degree of flexibility to the users. The SCHUNK VERO-S SEZ collet chuck modules are available for SCHUNK VERO-S NSE plus 138-V1 (ER 32-120 and ER 40-120), and VERO-S NSE mini 90-V1 (ER 25-100) quick-change pallet modules. The clamping diameter amounts from 2 to 20 mm (ER 32-120), 3 to 26 mm (ER 40-120), or 1 to 16 mm (ER 25-100). The maximum clamping depths is 96 mm (VERO-S SEZ), or 85 mm (VERO-S SEZ mini).

Contact: Satish Sadasivan;

Schunk Intec India Private Limited;

Ph.: 080-40538999;

Fax: 080-40538998;

Email: info@in.schunk.com;

Web: www.in.schunk.com



More efficient production thanks to tool presetting

Where the UNO series is concerned DMG MORI Microset relies on proven technology in tool presetting plus consistent further development. So the latest models combine optimum ergonomics with extensive technical equipment. “The diverse options ensure the UNO series a level of individualisation that is unmatched in this price category”, explains Lothar Sommer, MD, DMG MORI Microset GmbH.

In addition to a touch display, RFID chip system and post processors for all standard controls the range of potential equipment now also includes completely new options such as the autofocus and automatic drive. The UNO autofocus differs from the manual UNO in that it automatically focuses the cutting edge to be measured. This option proves enormously time-saving in particular for tools with several cutting edges around the circumference. In addition the UNO automatic drive positions the cutting edges automatically. No special knowledge is required of the user because the machine carries out fully automatic measurement of complex tools with several cutting edges and steps at the press of a button. In other words the UNO automatic drive constitutes an additional worker in tool presetting. The same manual operation as in the standard version is also possible with both equipment



Fully equipped UNO 20|40 in the “automatic drive” version

configurations if needed. The UNO autofocus and UNO automatic drive from DMG MORI Microset come with a comfort system cabinet and a 22” touch display in their standard versions.

The models of the UNO series are available in two sizes. The UNO 20|40 kicks off with a 400-mm traverse path in the Z-axis while the UNO 20|70 has a travel of 700 mm. Both versions are available as tabletop devices with a 19” screen. There is a 22” or 23” touch display available as an option as well as the comfort system cabinet. Unique here is the possibility of measuring tools with diameters up to 100 mm with the snap gauge principle even with the standard version thanks to a traverse path of +200 mm to -50 mm in the X-

axis. And of course all conventional tool interfaces such as HSK, Capto, VDI, KM or BMT can be realised by adapting the spindle in addition to the SK 50 that comes with the standard version.

A thermal label printer, vacuum clamping, a second camera for setting the centre of rotation and a multitude of other options round off the latest UNO series.

For more information, visit:

<http://in.dmgmori.com/products/presetters/tool-pre-setting-devices/uno>

UPDATE

CGTech joins Partners in THINC

Okuma America Corporation, a world leader in CNC machine tools, is pleased to announce that CGTech, a leading developer of CNC software specialising in simulations, verification, optimization and analysis technology for the manufacturing industry has joined Partners in THINC.

Members of Partners in THINC provide superior technologies that are integrated with Okuma’s CNC machines and controls to deliver advanced manufacturing system solutions.

Since 1988 CGTech’s product, VERICUT software, has been the industry standard for simulating CNC machining in order to detect errors, potential collisions, or areas of inefficiency. VERICUT enables users to eliminate the process of manually proving-out NC programs. The program also optimizes NC programs to both save time and produce higher quality surface finish. VERICUT simulates all types of CNC machine tools and runs standalone, but can also be integrated with most leading CAM systems.

“CGTech is excited to be a member of Partners in THINC

so that we may help end-users improve their manufacturing efficiency. By partnering with Okuma and Partners in THINC, CGTech can provide users with accurate machine simulations of Okuma machine tools to ensure that their tool paths are right the first time, every time,” said Jon Prun, President, CGTech.

“Okuma America is very pleased that CGTech has joined Partners in THINC. VERICUT will provide that next level of CNC program and toolpath verification prior to cutting the part. The use of VERICUT, along with a highly capable CAM package, allows Okuma’s customers to fully apply the capabilities and efficiencies of 5-axis machining,” said Jeff Estes, Director of Partners in THINC.

For more information on VERICUT software, CGTech, and other members of Partners in THINC,

visit <http://www.okuma.com/partners-in-thinc> or visit the CGTech website at cgttech.com

Meistermacher.
Made in Germany.

J. Lehmann

Jens Lehmann,
German goalkeeper legend,
SCHUNK brand ambassador since 2012
for precise gripping and safe holding.

German champion
with Borussia Dortmund 2002

English champion
with Arsenal London 2004

Claus Aichert,
Master –
Toolholders



www.gb.schunk.com/tendo-e-compact

70 Years

SCHUNK 

Superior Clamping and Gripping

SCHUNK Toolholders
More than **2,000,000**
times in use

SCHUNK precision toolholders.

The broadest technology spectrum of high-precision toolholding systems for μ -precise machining for higher productivity in your machining center.



TRIBOS-S.
Extremely compact design.



TRIBOS-Mini.
For micro-machining.



TENDO Original.
Diverse with 29 interfaces.



TRIBOS-SVL.
Super compact with optimized interfering contours.

Up to **300%**
longer tool life*

TENDO E compact

The universal hydraulic expansion holder with a torque of 2,000 Nm and a diameter of 32 mm.

* Verified in a study by the wbk Institute of Production Technology at the Karlsruhe Institute of Technology (KIT).



Are standard
catalogue products

Limiting Your Performance?

Many a time, a standard catalogue product limits your machining process and solutions. Trust TaeguTec to meticulously engineer and establish hi-performance Tailor-Made solutions for your demanding applications.



Our proficient Design and Application team is waiting for your call.

Your Partner In Cost Reduction.



Die & Mould



Wind Power



Shipbuilding



Railway



Miniature



Aerospace



Power Generation



Automotive



General

Always.

